

GCE

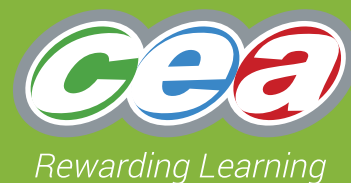

CCEA GCE Specification in Technology and Design

For first teaching from September 2022
For first award of AS level in Summer 2023
For first award of A level in Summer 2024
Subject Code: 8900



Contents

1	Introduction	3
1.1	Aims	4
1.2	Key features	4
1.3	Prior attainment	4
1.4	Classification codes and subject combinations	5
2	Specification at a Glance	6
3	Subject Content	8
3.1	Unit AS 1: Compulsory Paper – Design and Materials and Option Paper – Systems and Control or Product Design	8
3.2	Unit AS 2: Coursework – Product Development	23
3.3	Unit A2 1: Systems and Control or Product Design	25
3.4	Unit A2 2: Coursework – Product–System Design and Manufacture	34
4	Scheme of Assessment	37
4.1	Assessment opportunities	37
4.2	Assessment objectives	37
4.3	Assessment objective weightings	37
4.4	Quality of written communication	38
4.5	Synoptic assessment at A2	38
4.6	Higher order thinking skills	38
4.7	Reporting and grading	38
5	Grade Descriptions	40
6	Guidance on External Assessment	46
6.1	Unit AS 1: Compulsory Paper – Design and Materials and Option Paper – Systems and Control or Product Design	46
6.2	Unit A2 1: Systems and Control or Product Design	46
7	Guidance on Internal Assessment	47
7.1	Skills assessed by internal assessment	47
7.2	Setting the tasks	47
7.3	Taking the tasks	48
7.4	Marking the tasks	48
7.5	Internal standardisation	49
7.6	Moderation	49

8	Links and Support	50
8.1	Support	50
8.2	Curriculum objectives	50
8.3	Examination entries	51
8.4	Equality and inclusion	51
8.5	Contact details	52
	Appendix 1	53
	Assessment Criteria and Mark Bands	
	Appendix 2	60
	Symbols	

Subject Code	8900
QAN AS Level	601/8366/4
QAN A Level	601/8367/6

A CCEA Publication © 2022

This specification is available online at www.ccea.org.uk

1 Introduction

This specification sets out the content and assessment details for our Advanced Subsidiary (AS) and Advanced GCE courses in Technology and Design. First teaching is from September 2022.

Students can take:

- the AS course as a final qualification; or
- the AS units plus the A2 units for a full GCE A level qualification.

We assess the AS units at a standard appropriate for students who have completed the first part of the full course. A2 units have an element of synoptic assessment (to assess students' understanding of the subject as a whole), as well as more emphasis on assessment objectives that reflect higher order thinking skills.

The full Advanced GCE award is based on students' marks from the AS (40 percent) and the A2 (60 percent). The guided learning hours for this specification, as for all GCEs, are:

- 180 hours for the Advanced Subsidiary level award; and
- 360 hours for the Advanced level award.

We will make the first AS awards for the specification in 2023 and the first A level awards in 2024. The specification builds on the broad objectives of the Northern Ireland Curriculum.

If there are any major changes to this specification, we will notify centres in writing. The online version of the specification will always be the most up to date; to view and download this please go to www.ccea.org.uk

1.1 Aims

This specification aims to encourage students to:

- make use of tacit knowledge and reflective practices in order to work with tasks that are challenging and often need to be analysed and defined;
 - develop a lifelong interest in technology and design;
 - develop and sustain their creativity and innovative practice;
- develop higher order thinking skills, for example creative thinking and problem-solving, where appropriate;
- recognise and overcome challenges and constraints when working towards making high quality products;
 - draw on a range of skills and knowledge from other subject areas;
 - carry out research and present their findings in different formats;
- develop a critical understanding, from a contemporary perspective, of the influence of technology and design;
- draw on their knowledge, understanding and skills in making processes and apply these to a range of technological and design activities;
 - develop an understanding of contemporary technology and design practices; and
- use digital technologies and information handling skills to enhance their technological and design capability.

1.2 Key features

The following are important features of this specification.

- It includes four assessment units: two externally assessed and two internally assessed.
- It allows students to develop their subject knowledge, understanding and skills in relation to a work context.
- Assessment at A2 includes more question types, more demanding evaluative tasks, extended writing, and synoptic assessment that encourages students to develop their understanding of the subject as a whole.
 - It can give students a sound basis for progression to higher education.
- A range of support is available, including specimen assessment materials, exemplar schemes of work and teacher guidance.

1.3 Prior attainment

Students do not need to have reached a particular level of attainment before beginning to study this specification. However, the specification builds on knowledge, understanding and skills developed in GCSE Technology and Design.

1.4 Classification codes and subject combinations

Every specification has a national classification code that indicates its subject area. The classification code for this qualification is 8900.

Please note that if a student takes two qualifications with the same classification code, universities and colleges that they apply to may take the view that they have achieved only one of the two GCEs. The same may occur with any two GCE qualifications that have a significant overlap in content, even if the classification codes are different. Because of this, students who have any doubts about their subject combinations should check with the universities and colleges that they would like to attend before beginning their studies.

2 Specification at a Glance

The table below summarises the structure of the AS and A level courses:

Content	Assessment	Weightings	Availability
AS 1: Compulsory: Design and Materials Option: Systems and Control or Product Design	<p>One external written examination consisting of two papers:</p> <ul style="list-style-type: none"> Paper 1: Core area of study Students answer seven questions from a common core paper. Paper 2: Specialist area of study Students answer two questions that reflect the area of technology they chose to specialise in from the three options available. Option A: Electronic and Microelectronic Control Systems Option B: Mechanical and Pneumatic Control Systems Option C: Product Design <p>Each paper is 1 hour long. There will be a 20 minute break between papers.</p>	<p>50% of AS</p> <p>20% of A level</p>	<p>Every Summer from 2023</p>
AS 2: Coursework: Product Development	<p>Internal assessment</p> <p>Students complete one task, producing a practical outcome with a design folder.</p> <p>Teachers mark the task, and we moderate the results.</p>	<p>50% of AS</p> <p>20% of A level</p>	<p>Every Summer from 2023</p>

Content	Assessment	Weightings	Availability
<p>A2 1: Systems and Control <u>or</u> Product Design</p>	<p>External written examination 2 hours</p> <p>Students answer two questions from either Section A, Section B or Section C.</p>	<p>30% of A level</p>	<p>Every Summer from 2024</p>
<p>A2 2: Coursework: Product–System Design and Manufacture</p>	<p>Internal assessment</p> <p>Students complete one task, producing a practical outcome with a design folder.</p> <p>Teachers mark the task, and we moderate the results.</p>	<p>30% of A level</p>	<p>Every Summer from 2024</p>

3 Subject Content

We have divided this course into four units: two units at AS level and two units at A2. This section sets out the content and learning outcomes for each unit. Students studying this GCE Technology and Design Specification should be familiar with the symbols specified in Appendix 2.

3.1 Unit AS 1: Compulsory Paper – Design and Materials and Option Paper – Systems and Control or Product Design

Assessment for this unit consists of **one** external written examination with **two** papers. Each paper is **1** hour long and examined in one sitting. Students will have a 20 minute break between each paper.

This unit focuses on design and materials, including materials **and** their processing **and** an area of optional study, either:

- **Option A:** Electronic and Microelectronic Control Systems;
- **Option B:** Mechanical and Pneumatic Control Systems; or
- **Option C:** Product Design.

Compulsory area of study: Design and Materials

Students must study this core area. They must answer all **seven** questions in this paper based on the compulsory core section of the specification (1.1–1.10).

Optional area of study: Systems and Control or Product Design

Students must choose **one** area to study from:

- **Option A:** Electronic and Microelectronic Control Systems (1.11–1.17);
- **Option B:** Mechanical and Pneumatic Control Systems (1.18–1.23); or
- **Option C:** Product Design (1.24–1.31)

Students must answer **both** questions in their chosen option.

Content	Learning Outcomes
<p>1.3 Metal</p>	<p>Students should be able to:</p> <ul style="list-style-type: none"> • demonstrate knowledge of the available form of supply of metals; <ul style="list-style-type: none"> • understand the difference between ferrous and non-ferrous metals and alloys; • demonstrate knowledge and understanding of the properties, working characteristics and uses of: aluminium, aluminium alloys, copper, brass, zinc, steel (mild, medium and high) and stainless steel; • demonstrate an understanding of the main purposes and types of finishes for metals: painting, plastic coating, electroplating, anodising, enamelling and lacquering;
<p>1.4 Plastic</p>	<ul style="list-style-type: none"> • understand the difference between thermoplastic and thermosetting plastics; • demonstrate knowledge and understanding of the properties, working characteristics and uses for the following polymers: <ul style="list-style-type: none"> – high-density polyethylene (HDPE); – low-density polyethylene (LDPE); – polyethylene terephthalate (PET); – polystyrene; – polyvinyl chloride (PVC); – acrylic, nylon, acrylonitrile butadiene styrene (ABS); – melamine-formaldehyde; and – epoxy resins; and
<p>1.5 Modern composite and emerging technologies</p>	<ul style="list-style-type: none"> • demonstrate knowledge, understanding and applications for the following modern materials, and their application in product design, to include: <ul style="list-style-type: none"> – thermochromic and photochromic materials; – phosphorescent pigments; – reflective films and holograms; – liquid crystal displays; – polyether ether ketone (PEEK); – polyphenylsulfone (PPSU); and – graphene.

Content	Learning Outcomes
<p>1.6 Methods of processing materials</p> <p>1.7 Product analysis and improvement</p> <p>1.8 Design and communication</p>	<p>Students should be able to:</p> <ul style="list-style-type: none"> • demonstrate knowledge and understanding of: <ul style="list-style-type: none"> – wasting, including workshop hand tools, manual and computer numerical control (CNC) machine tools; – forming, including rolling, blanking, press forming and forging; – moulding, including injection moulding, blow moulding, rotational moulding, vacuum forming, sand casting and pressure die casting; and – extrusion; • analyse, evaluate and produce redesign proposals for existing products under the following headings: <ul style="list-style-type: none"> – form; – cost; – manufacture; – materials; – function; – performance; – aesthetics; – marketing constraints, target audience; – ergonomics and anthropometrics; – cultural, ethnic and moral issues; – environmental issues; and – user safety; • demonstrate knowledge and understanding of the design process, including: <ul style="list-style-type: none"> – design briefs; – research leading to the development of a specification; – generation of ideas; – design development and refining ideas; and – product review and testing; • demonstrate knowledge and understanding of the design process, in particular: <ul style="list-style-type: none"> – sustainability; and – creativity, flair and innovation; and • communicate designs using 2D methods, to include freehand sketching and mixed media.

Content	Learning Outcomes
<p>1.9 Design and manufacture</p> <p>1.10 Quality and safety</p>	<p>Students should be able to:</p> <ul style="list-style-type: none"> • demonstrate knowledge and understanding of the following: <ul style="list-style-type: none"> – computer-aided design (CAD), to include drawing, solid modelling, virtual imaging and rapid prototyping; – computer-aided manufacture (CAM) computers used to assist in a manufacturing process; – computer-integrated manufacture (CIM) computers used for stock control, quality control, manufacturing and assembly; and – the advantages of using CAD, CAM and CIM; • demonstrate knowledge and understanding of the use of: <ul style="list-style-type: none"> – factor of safety; and – tolerances; • demonstrate knowledge and understanding of the purpose of testing and inspection of components or products; and • demonstrate knowledge and understanding of the risks associated with common manufacturing and hand processes and methods used to minimise these.

**Optional area of study:
Option A – Electronic and Microelectronic Control Systems**

Content	Learning Outcomes
<p>1.11 Systems and control</p> <p>1.12 Safety</p> <p>1.13 Electronic components</p>	<p>Students should be able to:</p> <ul style="list-style-type: none"> • analyse electronic/microelectronic control systems in terms of input, control, output, on/off continuous control, and open and closed loop systems using feedback; • use appropriate circuit symbols and circuit diagrams for electronic/microelectronic systems; • demonstrate knowledge and understanding of the safety issues and procedures involved in the production, testing and use of electronic and microelectronic control systems in an educational environment; and • demonstrate knowledge and understanding of the following components: <ul style="list-style-type: none"> – resistors (colour code, E12 series, tolerance and power ratings); – capacitors – electrolytic and non-polarised; and – diodes (circuit protection with inductive loads).

Optional area of study: Option B – Mechanical and Pneumatic Control Systems

Content	Learning Outcomes
<p>1.18 Systems and control</p>	<p>Students should be able to:</p> <ul style="list-style-type: none"> • analyse mechanical and pneumatic control systems in terms of input, control, output, on/off continuous control, and open and closed loop systems using feedback; • use appropriate circuit symbols and circuit diagrams for mechanical and pneumatic systems;
<p>1.19 Safety</p>	<ul style="list-style-type: none"> • demonstrate knowledge and understanding of the safety issues and procedures used for mechanical and pneumatic control systems;
<p>1.20 Calculations</p>	<ul style="list-style-type: none"> • use given data and information to complete calculations for: <ul style="list-style-type: none"> – mechanical advantage and velocity ratio; – efficiency; – moments; – simple and compound velocity ratios and transmission speeds for gears, pulleys, and chains and sprockets; and – force, pressure and area associated with cylinders;
<p>1.21 Pneumatic and mechanical components</p>	<ul style="list-style-type: none"> • demonstrate knowledge and understanding of the operation of a compressor installation and the use of filter, regulator and lubricator units; and • demonstrate knowledge and understanding of the following pneumatic components: <ul style="list-style-type: none"> – three and five port valves with the following actuators (roller trip, one-way trip, plunger, push button, lever, solenoid, diaphragm and pilot operated); – single and double acting cylinders; – shuttle valves; – flow restrictors and reservoirs; and – piping and T connections.

Content	Learning Outcomes
<p>1.21 Pneumatic and mechanical components (cont.)</p> <p>1.22 Combining pneumatic and mechanical components</p>	<p>Students should be able to:</p> <ul style="list-style-type: none"> • represent these components using relevant standards to create the following: <ul style="list-style-type: none"> – time delay circuits; – logic circuits (AND, NOT and OR); – speed control of cylinders; – air bleed; – automatic reciprocation; and – circuits to control the movement of single and double acting cylinders; • demonstrate knowledge and understanding of the following mechanical components: <ul style="list-style-type: none"> – gears (spur, bevel, worm, rack and pinion); – pulleys and belts (single pulley, flat, round, vee and toothed belts); – fixed and self-adjusting jockey wheel or pulley; – crank and slider; – different types of motion (linear, rotary, oscillating and reciprocating); – first, second and third class levers; – linkages: bell crank and parallel; – cams (pear, heart, snail, eccentric and plate) and followers, to include knife, roller and flat, using terminology including rise, fall, dwell and stroke length; and – fixings to shafts, including grub screws, cotter pins, splines, and keys and keyways; and • demonstrate knowledge and understanding of how to: <ul style="list-style-type: none"> – convert motion using mechanical and/or pneumatic components; – combine simple and compound systems involving gears, pulleys, and chains and sprockets; – use gears, pulleys (belts), and chains and sprockets to change speed and/or direction of rotation; – use levers with linkages to meet specific requirements; and – combine mechanical and pneumatic components to produce systems with specific requirements.

Content	Learning Outcomes
1.23 Integrated application of mechanical and pneumatic control systems	Students should be able to: <ul style="list-style-type: none">• demonstrate knowledge and understanding of how to:<ul style="list-style-type: none">– combine pneumatic and mechanical components and/or systems in an industrial or commercial application; and– design pneumatic and mechanical systems suitable for integration with electrical or electronic control systems.

Content	Learning Outcomes
<p>1.25 Compliant, composite and smart materials (cont.)</p>	<p>Students should be able to:</p> <ul style="list-style-type: none"> • demonstrate knowledge and understanding of the characteristics and uses for the following smart materials: <ul style="list-style-type: none"> – shape memory alloys; – piezoelectric materials; and – light-emitting polymers.
<p>1.26 Design and communication</p>	<p>As well as the requirements of part 1.8 of the compulsory section of the specification, students should be able to:</p> <ul style="list-style-type: none"> • communicate designs using 2D and 3D methods, including: <ul style="list-style-type: none"> – freehand sketching; – pictorial, orthographic projection (third angle only); – isometric projection; – perspective; – assembly; – exploded drawings; and – modelling, including rapid prototyping; and • use these illustrations to communicate innovative design ideas.
<p>1.27 Methods of processing materials</p>	<p>Students should be able to:</p> <ul style="list-style-type: none"> • demonstrate knowledge and understanding of the following processes: <ul style="list-style-type: none"> – laminating; – steam bending; – die cutting; – water jet cutting; – laser cutting; – CNC router, milling and lathes; – 3D printing; and – dye sublimation.

Content	Learning Outcomes
<p>1.28 Quality and safety</p>	<p>As well as the requirements of part 1.10 of the compulsory section of the specification, students should be able to:</p> <ul style="list-style-type: none"> • demonstrate knowledge and understanding of safety requirements and how these relate to contemporary products, to include: <ul style="list-style-type: none"> – five stage risk assessment; – Health and Safety at Work Act (HASAWA); – Control of Substances Hazardous to Health (COSHH); – employee and consumer safety; – Trades Description Act; and – British Standards.
<p>1.29 Manufacturing production and quality systems</p>	<p>Students should be able to:</p> <ul style="list-style-type: none"> • demonstrate knowledge and understanding of scales of production, to include: <ul style="list-style-type: none"> – continuous production; – mass production; – batch production; and – one-off production; • demonstrate knowledge and understanding of how manufacturing is organised, to include: <ul style="list-style-type: none"> – cell production; – flexible manufacturing systems (FMS); – just in-time (JIT); – quick response manufacturing (QRM); and – Kanban and concurrent engineering; • demonstrate knowledge and understanding of the use of: <ul style="list-style-type: none"> – quality assurance (QA) and quality control (QC) systems; – ISO 9001 standards; and – statistical testing methods; • demonstrate knowledge and understanding of ‘right first time’ and continuous improvement; and
<p>1.30 Influences on product design</p>	<ul style="list-style-type: none"> • demonstrate knowledge and understanding of: <ul style="list-style-type: none"> – changes in fashion (miniaturisation; portability; flexibility); – cultural and social changes; and – scientific advances.

Content	Learning Outcomes
1.31 Intellectual property rights	Students should be able to: <ul style="list-style-type: none">• demonstrate knowledge and understanding of intellectual property rights and how these relate to contemporary products, to include the key issues of:<ul style="list-style-type: none">– design rights;– registered design;– patents;– trademarks; and– copyright.

3.2 Unit AS 2: Coursework – Product Development

The emphasis in this unit is on the analysis and development of an existing product with a view to redesigning either the product or an aspect of it. It is the responsibility of the teacher to ensure the choice of product allows sufficient scope for development and challenge at AS Level.

Students will produce a three dimensional model or prototype, which represents the practical outcome of the product analysis and development. Students should understand that the design process is **non-linear** and creativity should be evident throughout the process.

Students should submit a portfolio with the practical component. The portfolio should include written and graphical information produced on not more than 10 A3 sheets. Students can present the portfolio in electronic format, using a range of appropriate media.

This unit draws on the knowledge and skills covered in Unit AS 1 and should represent approximately 45 hours of work. It will be internally assessed and externally moderated.

Details of the requirements of each section are set out below. The learning outcomes describe what each student is expected to demonstrate in their portfolio and 3D model or prototype.

Skills Activity	Learning Outcomes
<p>1.32 Investigation and analysis of product</p>	<p>Students should be able to:</p> <ul style="list-style-type: none"> • identify a product with the aim of redesigning it or an aspect of it; • identify a range of existing similar products to the one chosen for redesign; • examine the function, purpose and design features of the range of existing similar products; • outline relevant materials and industrial production methods for the range of existing similar products; • evaluate the fitness for purpose of the range of existing similar products; • provide a detailed analysis of ergonomic and aesthetic qualities and product sustainability of the range of existing similar products; and • provide detailed referencing of all source material.

Skills Activity	Learning Outcomes
<p>1.33 Redesign solutions and development</p> <p>1.34 Making</p> <p>1.35 Testing and evaluation</p>	<p>Students should be able to:</p> <ul style="list-style-type: none"> • write a design specification for the proposed redesign; • generate a range of innovative and sustainable design modifications for the proposed redesign; • produce a range of annotated sketches of the proposed redesign; • evaluate the viability of the proposed redesign; • present a plan to be used in the making process of the proposed redesign; • produce a sequence of drawings that show the development of the proposed redesign; • produce final working drawings of the proposed redesign; • make a three dimensional model or prototype of the proposed redesign using appropriate material(s); • demonstrate a range of making skills and processes while making the model or prototype; • record any changes in design developments that occur during the making of the model or prototype; • evaluate the model or prototype in a critical and objective manner; • carry out a range of tests in order to evaluate the model or prototype; and • propose further development of the model or prototype following testing.

3.3 Unit A2 1: Systems and Control or Product Design

The unit focuses on an in-depth study of Systems and Control or Product Design.

Students must study either:

- **Option A:** Electronic and Microelectronic Control Systems;
- **Option B:** Mechanical and Pneumatic Control Systems; or
- **Option C:** Product Design.

Assessment for this unit consists of a written examination that includes both short and extended questions. For more details, see Section 6.

Students studying this GCE Technology and Design Specification should be familiar with the symbols specified in Appendix 2.

Option A: Electronic and Microelectronic Control Systems

Content	Learning Outcomes
<p>1.36 Systems and control</p>	<p>Students should be able to:</p> <ul style="list-style-type: none"> • analyse electronic or microelectronic control systems in terms of: <ul style="list-style-type: none"> – input; – control; – output; – on/off continuous control; and – open and closed loop systems using feedback; • use appropriate circuit symbols and circuit diagrams for electronic or microelectronic systems;
<p>1.37 Safety</p>	
<p>1.38 Input components</p>	

Content	Learning Outcomes
<p>1.39 Calculations</p> <p>1.40 PICs</p> <p>1.41 Output devices</p>	<p>Students should be able to:</p> <ul style="list-style-type: none"> • use knowledge and understanding of formulas, and information given to complete calculations for: <ul style="list-style-type: none"> – voltage divider circuits; – bridge circuits for strain gauge; – op-amp gain in inverting, non-inverting and differential modes; and – calculation of resistor in Zener diode power supplies; <i>(students need to know the relevant formulas, as we will not provide these in the assessment)</i> • demonstrate knowledge and understanding of flow charting, incorporating: input–output, loops, time delays, increment, flow control, subroutines and interrupts, to include: <ul style="list-style-type: none"> – awareness of commonly used PICs with digital I/O and with mixed digital and analogue I/O; and – interfacing with electronic systems employing a PIC; • employ PICs to control systems to meet specified requirements; and • demonstrate knowledge and understanding of: <ul style="list-style-type: none"> – seven segment display/common anode/common cathode; – LED bar array and liquid crystal displays (LCD), to include decoders and multiplexed displays; – Dot matrix displays; and – DC and stepper motors, to include characteristics of each and suitability for different applications; and • incorporate these devices into applications with suitable driving circuitry.

Content	Learning Outcomes
<p>1.42 Electronic systems</p>	<p>Students should be able to:</p> <ul style="list-style-type: none"> • demonstrate knowledge and understanding of: <ul style="list-style-type: none"> – Karnaugh maps to simplify truth tables with a maximum of three variables in logic systems; – op-amp circuits for various applications, including calculation of appropriate component values; – binary/BCD and up/down counters using negative edge triggering for clock and reset inputs; – binary counter as a frequency divider; – analogue to digital converters and digital to analogue converters; and – voltage regulation utilising voltage regulators and Zener diodes calculation of resistor in Zener diode power supplies; and • incorporate these systems into applications to meet specific requirements.

Option B: Mechanical and Pneumatic Control Systems

Content	Learning Outcomes
<p>1.43 Systems and control</p> <p>1.44 Safety</p> <p>1.45 Calculations</p> <p>1.46 Pneumatic components and systems</p>	<p>Students should be able to:</p> <ul style="list-style-type: none"> • analyse mechanical and pneumatic control systems in terms of input, control, output, on/off continuous control, and open and closed loop systems using feedback; • use appropriate circuit symbols and circuit diagrams for mechanical and pneumatic systems; • understand the limitations associated with the use of mechanical, pneumatic and hydraulic components and systems; • demonstrate knowledge and understanding of the safety issues and procedures used for mechanical and pneumatic control systems; • use given data and information to complete calculations for: <ul style="list-style-type: none"> – mechanical advantage and velocity ratio; – efficiency; – torque; – moments; – work, energy and power; – simple and compound velocity ratios and transmission speeds for gears, pulleys, and chains and sprockets; – force, pressure and area associated with cylinders; and – air consumption of cylinders; • demonstrate knowledge and understanding of the following pneumatic components: <ul style="list-style-type: none"> – vacuum pumps and vacuum lifting cups; – proximity sensors; and – use of 5/3 valves; • design sequential circuits to control up to four cylinders using positive feedback techniques; • design sequential/interlocking circuits using a maximum of four cascades; and • represent these components using appropriate symbols.

Content	Learning Outcomes
<p>1.47 Mechanical components and systems</p>	<p>Students should be able to:</p> <ul style="list-style-type: none"> • accurately draw cam profiles and performance diagrams: <ul style="list-style-type: none"> – to achieve dwell, uniform velocity, uniform acceleration and retardation and simple harmonic motion; – if the line of stroke of the follower is offset or inline with the centre of the cam; – using a range of followers, including knife edge and roller; and – to achieve a range of outcomes; and • demonstrate knowledge and understanding of: <ul style="list-style-type: none"> – gears, to include pitch circle diameter, pitch point, metric module, pinion wheel, simple and compound gear trains; – pulleys, to include simple and compound pulley systems, multiple pulley block and lifting systems; – chain and sprockets, to include simple and compound systems; – ratchet and pawl; – levers and linkages, to include bell crank, toggle and treadle; – shafts and couplings, to include aligned shafts, flexible couplings, universal joints, ball and socket, constant velocity; – joints and sliding couplings; – friction, to include static and dynamic; – brakes, to include cantilever, band, disc and drum; – clutches, to include cone, single plate, diaphragm and centrifugal; – methods employed to activate clutches and brakes; – bearings, to include plain, rolling element, self-aligning, thrust, taper and bearing housings; – lubrication, to include mechanics of lubrication, viscosity, classification of lubricants and applications; and – seals, to include O-ring, gasket, garter and seal housings; and
<p>1.48 Integrated application of mechanical and pneumatic control systems</p>	<ul style="list-style-type: none"> • combine mechanical and/or pneumatic/electrically actuated components to produce systems with specific industrial or commercial requirements.

Option C: Product Design

Content	Learning Outcomes
<p>1.49 Environmental issues</p>	<p>Students should be able to:</p> <ul style="list-style-type: none"> • describe the environmental issues relating to product design, to include: <ul style="list-style-type: none"> – environmental impact at different stages of the product life cycle; – climate change and greenhouse gases; – reducing environmental impact by design; – the 6Rs – rethink, reuse, recycle, repair, reduce and refuse – with practical examples; – environmental audits and life-cycle assessment; – reducing material use; – new technology and environmentally friendly manufacturing processes; – management of waste, the disposal of products and pollution control; – examples of national government and European Union influence; and – ethnic and cultural influences on the design and manufacture of products; • develop product design proposals that reflect the potential impact on the environment; • consider sustainability (embodied energy, responsible sourcing, recycled content) when selecting a material; and • demonstrate knowledge and understanding of: <ul style="list-style-type: none"> – the sustainable use of metals (for example recycled content, responsible sourcing and use of scarce metals); – the issues regarding sustainability in the manufacture and disposal of plastics; – the properties, working characteristics and uses of biodegradable and photodegradable plastics; and – the need for and benefits of innovation in product design with reference to improved performance and more sustainable use of resources.

Content	Learning Outcomes
<p>1.50 Product life cycle</p> <p>1.51 Advances in technology and ICT in manufacture</p> <p>1.52 From mind to market</p>	<p>Students should be able to:</p> <ul style="list-style-type: none"> • explain the product life cycle, to include: <ul style="list-style-type: none"> – inception, introduction, growth, maturity and decline; – life cycle for fad, fashion and basic products; and – product redesign (reasons, alternatives, relaunch of products, product testing, and identification of problems with existing products); • employ CAD and CAM systems and other ICT systems where appropriate in the design and manufacture of products; • explain to the designer the benefits of: <ul style="list-style-type: none"> – CAD, CAM and CNC; – 3D scanning; – quick response manufacturing (QRM); – quick change injection moulding techniques; – Kanban; and – flexible manufacturing systems (FMS); and • describe the role of markets in product design, to include: <ul style="list-style-type: none"> – market research; – needs and demands; – how and why new products arise; – innovation in the market; – key aspects of market pull and technology push; – key aspects of radical and incremental products; and – market strategy – key concepts of market penetration, market development, product development and diversification.

Content	Learning Outcomes
<p>1.52 From mind to market (cont.)</p> <p>1.53 Quality control and assurance</p> <p>1.54 Design for use</p>	<p>Students should be able to:</p> <ul style="list-style-type: none"> • explain the four Ps: <ul style="list-style-type: none"> – Product, to include: <ul style="list-style-type: none"> variable product life cycles; variation between the life cycles of products; and the five types of consumers who emerge at each stage of the life cycle, (fashion innovators, opinion leaders, masses, late adopters and laggards); – Price, to include: <ul style="list-style-type: none"> determining the price and the elasticity of demand; pricing methods, to include cost-plus, contribution pricing and perceived value; and pricing strategy for each of the stages of the life cycle of the product; – Place, to include: <ul style="list-style-type: none"> geographical placing – international and regional differences, difficulties and barriers to trading; and physical placing – getting the product to the right place at the right time; and – Promotion, to include: <ul style="list-style-type: none"> sales promotion, advertising processes, publicity, personal selling, exhibitions and trade fairs; and development of promotional strategies for a range of products; • describe the use of ICT to implement the four Ps; • develop an understanding of the various processes and strategies employed in quality control and assurance systems, for example using measuring devices, jigs, templates and fixtures; • describe the use of ICT in quality control and assurance; <ul style="list-style-type: none"> • design for maintenance and repair; and • design to be inclusive for all society.

Content	Learning Outcomes
<p>1.55 Design for manufacture</p> <p>1.56 Design and communication</p> <p>1.57 Technological developments in society</p>	<p>Students should be able to:</p> <ul style="list-style-type: none"> • formulate proposals for product design and development taking account of the need for scale production; • design to minimise materials, components, processes and the environmental impact; • design to minimise packaging material and wasted packaging space; • use appropriate communication methods and rendering techniques to demonstrate innovative design ideas; • use text size and style to communicate impact, product information and appeal to a variety of audiences; • describe the influence of the following designers and movements in product design: <ul style="list-style-type: none"> – Dyson; – Bayliss; – Memphis; and – Apple; and • describe examples of designs that incorporate moral economic, social and environmental factors.

3.4 Unit A2 2: Coursework – Product–System Design and Manufacture

In this unit, students develop and showcase a wide range of technical, design and making skills and capabilities in response to a client-focused, real world need.

Students design and make a product that includes a technological system or a range of product design features. They must identify an appropriate problem or need and ensure it provides sufficient scope to meet the assessment criteria.

Students should understand that the design process is **non-linear** and creativity should be evident throughout the process.

It is the teacher’s responsibility to ensure that the topic chosen allows sufficient scope and intellectual challenge appropriate to an A2 course.

The final outcome must have an energy source to make it function and include a control system comprising input, process and output **or** incorporate a range of product design features.

Students should submit a portfolio with the practical component. The portfolio should include written and graphical information produced on not more than 20 A3 sheets. Students can present the portfolio in electronic format, using a range of appropriate media.

This unit draws on the knowledge and skills covered in all units but must reflect the option chosen in Unit A2 1. It represents approximately 60 hours of work. Teachers assess this unit and we moderate it.

Details of the requirements of each section are set out below. The learning outcomes describe what each student is expected to demonstrate in their portfolio and in their product.

Skills Activity	Learning Outcomes
<p>1.58 Identification of problem, client or end user needs and specification</p>	<p>Students should be able to:</p> <ul style="list-style-type: none"> • identify a problem or need; • formulate a design brief for the problem or need; • identify potential clients or end users; and • consider design implications arising from the needs of potential clients or end users.

Skills Activity	Learning Outcomes
<p>1.58 Identification of problem, client or end user needs and specification (cont.)</p> <p>1.59 Initial ideas, appraisal and selection</p> <p>1.60 Development</p>	<p>Students should be able to:</p> <ul style="list-style-type: none"> • analyse existing solutions to the problem or need using a range of research techniques; • formulate a design specification that allows for concept development; • provide detailed referencing of all source material; • propose appropriate and innovative design outcomes that integrate either Systems and Control or Product Design features; • evaluate each proposal using relevant criteria; • select a concept that is appropriate for development; • develop the chosen concept; • provide evidence of numerical analysis used in developing the concept; • provide documentary evidence of making and design decisions made during development; • justify decisions made during development; • develop a concept that integrates with both the user and the environment; • provide evidence of ergonomic and aesthetic development of the concept; • provide a detailed plan of the making process employed; and • produce working drawings for the making process.

4 Scheme of Assessment

4.1 Assessment opportunities

Each unit is available for assessment in summer each year. It is possible to resit individual AS and A2 assessment units once and count the better result for each unit towards an AS or A level qualification. Candidates' results for individual assessment units can count towards a qualification until we withdraw the specification.

4.2 Assessment objectives

There are two assessment objectives for this specification. Candidates must:

- demonstrate specific knowledge and understanding; be able to apply that knowledge and understanding in combination with appropriate skills in their designing; communicate ideas and outcomes and demonstrate strategies for evaluation (AO1); and
- be able to demonstrate and apply skills, knowledge and understanding of relevant materials, processes and techniques; use equipment and materials to produce suitable and appropriate outcomes; communicate ideas and outcomes and demonstrate strategies for evaluation (AO2).

4.3 Assessment objective weightings

The table below sets out the assessment objective weightings for each assessment unit and the overall A level qualification:

Percentage Assessment Objective Weightings				
	AO1	AO2	AS	A level
AS 1	14.5	5.5	20	20
AS 2	6.8	13.2	20	20
A2 1	21.8	8.2		30
A2 2	6.9	23.1		30
Total	50	50	40	100

4.4 Quality of written communication

In AS and A level Technology and Design, candidates must demonstrate their quality of written communication. They need to:

- ensure that text is legible and that spelling, punctuation and grammar are accurate so that meaning is clear;
- select and use a form and style of writing that suit their purpose and complex subject matter; and
- organise information clearly and coherently, using specialist vocabulary where appropriate.

Quality of written communication is assessed in responses to questions and tasks that require extended writing.

4.5 Synoptic assessment at A2

The A2 assessment units include some synoptic assessment, which encourages candidates to develop their understanding of the subject as a whole. In our GCE Technology and Design, synoptic assessment involves:

- building on material from the AS units;
- bringing together and making connections between areas of knowledge and skills that they have explored throughout the course;
- combining their designing and making skills with knowledge and understanding in various tasks;
- following their own lines of enquiry and recording and observing from a range of sources of research material; and
- responding to a design brief or problem.

4.6 Higher order thinking skills

The A2 assessment units provide opportunities to demonstrate higher order thinking skills by incorporating:

- a wider range of question types to address different skills, for example problem solving in unfamiliar contexts and scenarios;
- more demanding evaluative tasks;
- questions that require candidates to make more connections between sections of the specification; and
- extended writing.

4.7 Reporting and grading

We report the results of individual assessment units on a uniform mark scale that reflects the assessment weighting of each unit.

We award AS qualifications on a five grade scale from A to E, with A being the highest. We award A level qualifications on a six grade scale from A* to E, with A* being the highest. To determine candidates' grades, we add the uniform marks obtained in individual assessment units.

To be awarded an A*, candidates need to achieve a grade A on their full A level qualification and at least 90 percent of the maximum uniform marks available for the A2 units. If candidates fail to attain a grade E, we report their results as unclassified (U).

The grades we award match the grade descriptions in Section 5 of this specification.

5 Grade Descriptions

Grade descriptions are provided to give a general indication of the standards of achievement likely to have been shown by candidates awarded particular grades. The descriptions must be interpreted in relation to the content in the specification; they are not designed to define that content. The grade awarded depends in practice upon the extent to which the candidate has met the assessment objectives overall. Shortcomings in some aspects of candidates' performance in the assessment may be balanced by better performances in others.

The requirement for all AS and A level specifications to assess candidates' quality of written communication will be met through both assessment objectives AO1 and AO2.

AS Grade Descriptions

Grade	Description
AS Grade A	For AO1, candidates characteristically: <ul style="list-style-type: none"> • demonstrate specific knowledge and understanding of the working characteristics of materials, components and their uses and/or systems and control; • develop an appropriate brief and specification; • understand quality issues; • use correct technical language relevant to the task; • research and communicate a broad range of ideas and information effectively in a creative and innovative way through some recognition of values, issues or uniqueness (for the candidate) or connections with other ideas; • demonstrate that they understand the main features of industrial and commercial practices related to manufacturing systems, including the use of ICT and stages of production; • show that they understand health and safety issues through the regulatory and legislative framework; • demonstrate clear strategies for testing and evaluating by taking into account form and function of a product, trends and styles of products reflecting environmental, cultural and ethical or moral issues as well as stylistic and engineering considerations; and • analyse and assess information and ideas in appropriate ways, including ICT, enabling others to interpret them.

Grade	Description
	<p>For AO2, candidates characteristically:</p> <ul style="list-style-type: none"> • apply skills that demonstrate understanding of the working characteristics and potential application of a range of materials, components and/or systems and control, including preparation and processing; • demonstrate that they understand the principles of testing materials and/or components; • demonstrate that they understand and can carry out appropriate making processes during product development or manufacture; • understand and use safe working practices; • use appropriate skills to develop a practical outcome; • communicate ideas and outcomes; • refine and/or modify products and/or manufacturing methods; • use a range of criteria, for example social, economic, environmental, cultural and ethical or moral considerations; and • demonstrate clear strategies for testing and evaluating by analysing the planning, production and manufacturing methods.

Grade	Description
<p>AS</p> <p>Grade E</p>	<p>For AO1, candidates characteristically:</p> <ul style="list-style-type: none"> • demonstrate some understanding of how their knowledge and understanding of materials, components and their uses meet general design criteria; • develop an outline brief and specification; • communicate ideas and information appropriately; • demonstrate that they understand at least one feature of industrial and commercial practices, a relevant manufacturing system and some stages of production; and • demonstrate some strategies for testing and evaluating by taking into account form and function of a product and the need for appropriate modifications. <p>For AO2, candidates characteristically:</p> <ul style="list-style-type: none"> • demonstrate that they understand the application of a limited range of materials and components, including their uses; • demonstrate some knowledge of testing a material or component; • demonstrate that they understand and can carry out a limited range of making processes safely during product development; • demonstrate that they understand how to plan for production; • communicate ideas and outcomes through a suitable development process and manufacturing method; and • demonstrate the ability to test and evaluate a limited range of manufacturing methods.

A2 Grade Descriptions

Grade	Description
A2 Grade A	<p>For AO1, candidates characteristically:</p> <ul style="list-style-type: none"> • demonstrate specific ability to analyse questions and/or contexts and select and explain relevant ways to proceed during in-depth study; • take account of a wide range of factors and show knowledge and understanding of materials and manufacturing processes; • combine distinct elements of technical information in their responses; • develop an initial design brief and an outline specification and produce a design for manufacturing, considering maintenance and product life; • clarify the task during the designing and making activities, identifying a wide range of user needs; • carry out in-depth research, including some relevant primary research; • originate a range of ideas and possible solutions when generating and developing proposals; • apply knowledge and understanding to develop and refine their solutions, demonstrating evidence of creativity and innovation through recognition of values, issues or uniqueness (for the candidate) or connections with other ideas; • research, analyse and communicate a broad range of ideas and information effectively; • use technical language fluently, draw appropriate conclusions and model aspects of their ideas when developing proposals; • demonstrate clear strategies for testing and evaluating by taking into account: <ul style="list-style-type: none"> – the working characteristics of materials and components; – the products' impact on society; and – the precise requirements of the brief or specification; and • confidently analyse ideas and outcomes and draw highly appropriate conclusions, enhancing interpretation by others.

Grade	Description
	<p>For AO2, candidates characteristically:</p> <ul style="list-style-type: none"> • demonstrate their understanding of systems and control and/or products and applications by discriminating between aspects of a system or product that perform and those that could be improved after in-depth study; • demonstrate an understanding of reliable and quantifiable performances of a range of materials, components and production processes; • demonstrate applied knowledge of the working properties and functions of materials and components; • work safely, accurately and skilfully with materials, components, tools and processes, including appropriate technologies to create high-quality products that match the specification; • plan, demonstrating an awareness of industrial methods and approaches during designing and making activities; • select an appropriate range of tools and equipment and plan processes; • manage time by anticipating potential problems and responding to changing circumstances; • determine the degree of accuracy required for products to function as intended, and apply relevant external standards to their task; • test the performance of their product against specified criteria and act on their findings by modifying their proposals if appropriate; • communicate ideas and outcomes using ICT appropriately for communicating, modelling, data handling, controlling or manufacture; • work to devised plans and seek agreement on realistic deadlines; • take account of the relationship between material, form and manufacturing processes; and • demonstrate clear strategies for evaluating, by: <ul style="list-style-type: none"> – analysing information critically and objectively; – assessing the extent to which their work will meet genuine needs; and – devising quality assurance procedures and reviewing the way the work plan is followed using external sources for evaluating products.

Grade	Description
<p>A2</p> <p>Grade E</p>	<p>For AO1, candidates characteristically:</p> <ul style="list-style-type: none"> • demonstrate their ability to analyse questions and/or contexts and record some relevant information during in-depth study; • take account of a limited range of factors; • take account of requirements and demonstrate some knowledge and understanding of manufacturing processes during product analysis; • develop a design brief and specification; • use technical language relevant to the task; • clarify the task, identifying user needs; • carry out research during designing and making activities; • generate ideas based on their own knowledge and understanding, satisfying most of the specification criteria; • show awareness of manufacturing processes; • develop their proposals and model at least one aspect; • indicate at least one working characteristic of a material or component; • demonstrate some strategies for testing and evaluating that refer to products and the need for modifications; and • evaluate ideas and outcomes in an appropriate way, including ICT, and draw conclusions enabling others to understand them. <p>For AO2, candidates characteristically:</p> <ul style="list-style-type: none"> • demonstrate a basic understanding of systems and control and/or products and applications during in-depth study; • demonstrate some understanding of a limited range of materials, components and production processes; • work safely with materials and components to create a product that meets their specification; • plan, demonstrating some awareness of industrial methods, during making activities; • select some appropriate tools and resources; • carry out at least one test of their product; • work to an outline plan; • use ICT appropriately for communicating, modelling, data handling, controlling or manufacture; • demonstrate strategies for testing and evaluating; • analyse information; and • assess the extent to which the product meets its specification.

6 Guidance on External Assessment

There are **two** external assessment units in this specification, one at AS level and one at A2:

- **Unit AS 1: Compulsory Paper** – Design and Materials and **Option Paper** – Systems and Control **or** Product Design; and
- **Unit A2 1: Systems and Control **or** Product Design.**

The external assessment focuses on candidates' knowledge, understanding and analysis of the content of each unit.

6.1 Unit AS 1: Compulsory Paper – Design and Materials and Option Paper – Systems and Control or Product Design

Assessment for this unit consists of one external written examination with two papers. Each paper is **1** hour long and examined in one sitting. Candidates have a 20 minute break between both papers. Candidates display and apply their knowledge of the content of the AS 1 unit by answering a series of questions requiring short responses using text and graphics.

Compulsory area of study: Paper 1 – Design and Materials

Candidates must study this core area. Candidates must answer all seven questions in this paper based on the compulsory core section of the specification (1.1–1.10).

Optional area of study: Paper 2 – Systems and Control **or** Product Design

Candidates choose to study **one** option from the following three options:

- **Option A:** Electronic and Microelectronic Control Systems (1.11–1.17);
- **Option B:** Mechanical and Pneumatic Control Systems (1.18–1.23); or
- **Option C:** Product Design (1.24–1.31).

Candidates must answer **both** questions in their chosen option.

6.2 Unit A2 1: Systems and Control or Product Design

In this unit, candidates choose to study **one** option from the following three options:

- **Option A:** Electronic and Microelectronic Control Systems (1.36–1.42);
- **Option B:** Mechanical and Pneumatic Control Systems (1.43–1.48); or
- **Option C:** Product Design (1.49–1.57).

Assessment for this unit consists of **one** external written examination. The paper is **2** hours long. Candidates display and apply their knowledge of the content of Unit A2 1 by answering a series of questions requiring short and long responses using text and graphics.

Candidates must answer **both** questions in their chosen option.

7 Guidance on Internal Assessment

There are two internal assessment units in this specification, one at AS level and one at A2:

- Unit AS 2: Product Development; and
- Unit A2 2: Product–System Design and Manufacture.

The internal assessment focuses on candidates' ability to apply their knowledge and skills.

7.1 Skills assessed by internal assessment

Teachers must assess the following skills through internal assessment:

- problem identification;
- research;
- generation of ideas;
- making; and
- evaluation.

There may also be external assessment of elements of all these skills.

7.2 Setting the tasks

It is essential that the teacher acts as facilitator and ensures that the task the candidate undertakes is appropriate and achievable. Teachers should give guidance in the planning and realisation of each internal assessment task to ensure that:

- the task is reasonable and the candidate can complete it effectively in the time available;
- the work meets the relevant requirements of the specification;
- the work can be assessed using the specified assessment criteria;
- the candidate produces work unaided, except for appropriate guidance from the teacher;
- tasks do not contravene Health and Safety at Work legislation; and
- the candidate's school or college can facilitate the design and realisation of the task.

7.3 Taking the tasks

Internal assessment is likely to involve both work in the classroom and independent study. It is essential to manage the assessment conditions in a way that ensures the assessment remains reliable and fair. The following table sets out the requirements.

Area	Assessment Conditions
Supervision	Teachers should supervise candidates' work to: <ul style="list-style-type: none"> • monitor their progress; • prevent plagiarism and check that the work that candidates submit is their own; • comply with health and safety requirements; • provide advice and guidance if there are any problems; and • ensure that the work aligns with the specification requirements and can be marked using the criteria set out for each unit.
Authenticity	Teachers must be aware of any third party copyright or intellectual property issues in candidates' work. They must sign a declaration to certify that, to the best of their knowledge, all the work that candidates have submitted for assessment is their own.
Time Limit/ Word Limit	Unit AS 2 should comprise not more than 10 A3 pages and represent 45 hours of work. Unit A2 2 should comprise not more than 20 A3 pages and represent 60 hours of work.
Collaboration	Candidates must work independently when completing their internal assessment tasks. Individual candidates' work may be informed by working with others, but each candidate must provide an individual response.
Resources	Candidates must appropriately reference all the materials they use in their work, including any online resources.

7.4 Marking the tasks

Teachers should use their professional judgement to apply the criteria in the mark bands appropriately and fairly to candidates' work. They should take a 'best fit' approach to award the appropriate mark within a range, balancing strengths and weaknesses in each response.

For up-to-date advice on plagiarism, or any kind of candidate malpractice, see *Suspected Malpractice in Examinations and Assessments: Policies and Procedures* on the Joint Council for Qualifications website at www.jcq.org.uk

7.5 Internal standardisation

Centres with more than one teaching group must carry out internal standardisation of their internal assessment tasks before submitting their marks to us. This is to ensure, as far as possible, that each teacher has applied the assessment criteria consistently. It may be necessary to adjust an individual teacher's marking:

- to bring it into line with that of other teachers in the centre; and
- to match the standards established at the agreement trial.

7.6 Moderation

Centres must submit their marks and samples to us by May in any year. We may adjust centres' marking to bring the assessment of candidates' work into line with our agreed standards.

We issue full instructions each year on:

- our moderation procedures;
- which samples we require; and
- the deadlines for submitting marks and samples to us.

Teachers and centre staff may contact us at any stage for advice or support relating to internal assessment.

8 Links and Support

8.1 Support

The following resources are available to support this specification:

- our Technology and Design microsite at www.ccea.org.uk
- specimen assessment materials; and
- guidance notes for teachers.

We also intend to provide:

- past papers and mark schemes;
- Chief Examiner's reports;
- Principal Moderator's reports;
- schemes of work;
- centre support visits;
- support days for teachers;
- agreement trials;
- a resource list; and
- exemplification of standards.

8.2 Curriculum objectives

This specification supports centres to build on the broader Northern Ireland Curriculum objectives to develop the young person:

- as an individual;
- as a contributor to society; and
- as a contributor to the economy and environment.

It can contribute to meeting the requirements of the Northern Ireland Entitlement Framework at post-16 and the provision of a broad and balanced curriculum.

Curriculum Progression from Key Stage 4

This specification builds on learning from Key Stage 4 and gives students opportunities to develop their subject knowledge and understanding further.

Students will also have opportunities to continue to develop the **Cross-Curricular Skills** and the **Thinking Skills and Personal Capabilities** shown below. The extent of this development depends on the teaching and learning methodology the teacher uses.

Cross-Curricular Skills

- Communication:
 - Talking and Listening
 - Reading
 - Writing
- Using Mathematics
- Using ICT

Thinking Skills and Personal Capabilities

- Problem Solving
- Working with Others
- Self-Management

For further guidance on the skills and capabilities in this subject, please refer to the supporting schemes of work.

8.3 Examination entries

Entry codes for this subject and details on how to make entries are available on our Qualifications Administration Handbook microsite, which you can access at www.ccea.org.uk

Alternatively, you can telephone our Examination Entries, Results and Certification team using the contact details provided.

8.4 Equality and inclusion

We have considered the requirements of equality legislation in developing this specification and designed it to be as free as possible from ethnic, gender, religious, political and other forms of bias.

GCE qualifications often require the assessment of a broad range of competences. This is because they are general qualifications that prepare students for a wide range of occupations and higher level courses.

During the development process, an external equality panel reviewed the specification to identify any potential barriers to equality and inclusion. Where appropriate, we have considered measures to support access and mitigate barriers.

We can make reasonable adjustments for students with disabilities to reduce barriers to accessing assessments. For this reason, very few students will have a complete barrier to any part of the assessment.

Students with a physical disability may be limited in the range of designing and making contexts they can use, but this should not be a barrier to assessment. For example, students with physical disabilities may use CAD/CAM for the making process with practical assistants to support them. Students with a visual impairment may find elements of the assessment, such as graphics, difficult, but there should be no additional barriers to assessment.

It is important to note that where access arrangements are permitted, they must not be used in any way that undermines the integrity of the assessment. You can find information on reasonable adjustments in the Joint Council for Qualifications document *Access Arrangements and Reasonable Adjustments: General and Vocational Qualifications*, available at www.jcq.org.uk

8.5 Contact details

If you have any queries about this specification, please contact the relevant CCEA staff member or department:

- Specification Support Officer: Nuala Tierney
(email: ntierney@ccea.org.uk)
- Education Manager: Judith Ryan
(email: jryan@ccea.org.uk)
- For a full list of contacts within CCEA visit our website at www.ccea.org.uk/examiner-centre-support/examinations-support/key-contacts

Appendix 1

Assessment Criteria and Mark Bands for Unit AS 2: Product Development

Communication: candidates should present their information for assessment in a coherent and concise manner using a range of formats, including ICT, illustrations, extensive photographs, annotated sketches, text and other appropriate media.

Candidates should reference all source material clearly.

Investigation and Analysis of Product						
Assessment Objectives	High Mark Band	Mark	Medium Mark Band	Mark	Low Mark Band	Mark
AO1 AO2	<p>Candidates:</p> <ul style="list-style-type: none"> • present a wide range of existing similar products in detail • give a detailed description of function, purpose and features • provide an in-depth consideration of relevant materials and industrial production methods • present a detailed evaluation of fitness for purpose • present high level analysis of ergonomics, sustainability and aesthetic suitability. 	7–10	<p>Candidates:</p> <ul style="list-style-type: none"> • present a good range of existing similar products in moderate detail • give a good description of function, purpose and features • provide some consideration of relevant materials and industrial production methods • present an evaluation of fitness for purpose with some detail • present a good analysis of ergonomics, sustainability and aesthetic suitability. 	4–6	<p>Candidates:</p> <ul style="list-style-type: none"> • present only a narrow range or list of existing similar products • give a short description of function, purpose and features • provide a superficial consideration of relevant materials and industrial production methods • present a superficial evaluation of fitness for purpose • present a basic analysis of ergonomics, sustainability and aesthetic suitability. 	1–3
Award zero for work not worthy of credit.						

Redesign Solutions and Development						
Assessment Objectives	High Mark Band	Mark	Medium Mark Band	Mark	Low Mark Band	Mark
AO1 AO2	<p>Candidates:</p> <ul style="list-style-type: none"> • write a detailed redesign specification • generate a range of innovative and sustainable design modifications using high quality annotated sketches • evaluate in detail the viability of each modification • present a detailed plan for the making process • produce a detailed sequence of redesign development drawings • produce high level working drawings for the making process. 	29–40	<p>Candidates:</p> <ul style="list-style-type: none"> • write a good redesign specification • generate a good range of innovative and sustainable design modifications using adequately annotated sketches • evaluate with some detail the viability of each modification • present a plan for the making process with some detail • produce a limited sequence of redesign development drawings • produce good working drawings for the making process. 	13–28	<p>Candidates:</p> <ul style="list-style-type: none"> • write a basic redesign specification • generate an innovative and sustainable design modification using adequately annotated sketches • evaluate in superficial detail the viability of each modification • present a superficial plan for the making process • produce a superficial sequence of redesign development drawings • produce poor working drawings for the making process. 	1–12
Award zero for work not worthy of credit.						

Making, and Testing and Evaluation						
Assessment Objectives	High Mark Band	Mark	Medium Mark Band	Mark	Low Mark Band	Mark
AO1 AO2	Candidates: <ul style="list-style-type: none"> • produce a high quality outcome using appropriate material(s) • demonstrate a high level of competence in a range of making skills and processes • record in detail any changes in design developments brought about during the making process 	29–40	Candidates: <ul style="list-style-type: none"> • produce a good quality outcome using appropriate material(s) • demonstrate a good level of competence in a range of production skills and processes • record with some detail changes in design developments brought about during the making process 	13–28	Candidates: <ul style="list-style-type: none"> • produce a low quality outcome using appropriate material(s) • demonstrate a basic level of competence in a range of production skills and processes • record basic changes in design developments brought about during the making process 	1–12
AO2	<ul style="list-style-type: none"> • produce a high level critical and objective evaluation of the outcome • carry out an extensive range of detailed testing, showing meaningful conclusions • make high level proposals for further development as an outcome of testing. 	7–10	<ul style="list-style-type: none"> • produce a good critical and objective evaluation of the outcome • carry out a good range of testing, showing mostly meaningful conclusions • make some proposals for further development as an outcome of testing. 	4–6	<ul style="list-style-type: none"> • produce basic evaluation of the outcome • carry out basic testing, showing little meaningful conclusions • make only superficial proposals for further development as an outcome of testing. 	1–3
Award zero for work not worthy of credit.						

Assessment Criteria and Mark Bands for Unit A2 2: Product–System Design and Manufacture

Communication: candidates should present their information for assessment in a coherent and concise manner using a range of formats, including ICT, illustrations, extensive photographs, annotated sketches, text and other appropriate media.

Candidates should reference all source material clearly.

Identifying a Problem, Client or User Needs and Design Specification						
Assessment Objectives	High Mark Band	Mark	Medium Mark Band	Mark	Low Mark Band	Mark
AO1 AO2	<p>Candidates:</p> <ul style="list-style-type: none"> identify the problem or need leading to a detailed design brief identify the potential client or end user with relevant consideration of associated design implications analyse existing solutions, using a range of research techniques propose a design specification supporting excellent development of ideas provide detailed evidence of referencing source material. 	7–10	<p>Candidates:</p> <ul style="list-style-type: none"> make some identification of the problem or need leading to a design brief with some detail identify the potential client or end user with some consideration of associated design implications analyse existing solutions using a good range of research techniques propose a design specification supporting good development of ideas provide some evidence of referencing source material. 	4–6	<p>Candidates:</p> <ul style="list-style-type: none"> make a superficial identification of the problem or need leading to a poor design brief identify the potential client or end user with limited consideration of associated design implications analyse existing solutions using basic research techniques propose a basic design specification supporting superficial development of ideas provide limited evidence of referencing source material. 	1–3
Award zero for work not worthy of credit.						

Initial Ideas, Selection of Ideas for Development						
Assessment Objectives	High Mark Band	Mark	Medium Mark Band	Mark	Low Mark Band	Mark
AO1 AO2	<p>Candidates:</p> <ul style="list-style-type: none"> produce innovative design outcomes, integrating either systems and control or product design features evaluate each concept in detail, based on relevant criteria select a concept suitable for detailed development. 	14–20	<p>Candidates:</p> <ul style="list-style-type: none"> produce good design outcomes with some innovation, integrating either systems and control or product design features make an evaluation of each concept based on relevant criteria with some detail select a concept suitable for development with some detail. 	7–13	<p>Candidates:</p> <ul style="list-style-type: none"> produce basic design outcomes lacking innovation, integrating either systems and control or product design features make a superficial evaluation of each concept based on relevant criteria select a concept suitable only for superficial development. 	1–6
Award zero for work not worthy of credit.						

Development						
Assessment Objectives	High Mark Band	Mark	Medium Mark Band	Mark	Low Mark Band	Mark
AO1 AO2	<p>Candidates:</p> <ul style="list-style-type: none"> develop the control system or product to an excellent final outcome present detailed evidence of numerical analysis in development document making and design decisions with detailed justification to support the decisions made during development develop the concept to integrate with the user and environment appropriately present appropriate evidence of ergonomic and aesthetic development present a detailed plan of the making process produce detailed working drawings for the making process. 	14–20	<p>Candidates:</p> <ul style="list-style-type: none"> develop the control system or product to a good outcome present limited evidence of numerical analysis in development with some detail document making and design decisions with some justification to support the decisions made during development develop the concept to integrate with the user and environment with some limitations present some evidence of ergonomic and aesthetic development present a plan of the making process with some detail produce good working drawings for the making process with some detail. 	7–13	<p>Candidates:</p> <ul style="list-style-type: none"> develop the control system or product to a limited outcome present superficial evidence of numerical analysis in development document making and design decisions with superficial justification to support the decisions made during development develop the concept to integrate with the user and environment with a range of limitations present basic evidence of ergonomic and aesthetic development present a basic plan of the making process produce basic working drawings for the making process. 	1–6
Award zero for work not worthy of credit.						

Making, and Testing and Evaluation						
Assessment Objectives	High Mark Band	Mark	Medium Mark Band	Mark	Low Mark Band	Mark
AO1 AO2	<p>Candidates:</p> <ul style="list-style-type: none"> • produce a high quality outcome incorporating a range of components or product design features and materials reflective of the design decisions taken during development • demonstrate high level competence in a range of making skills and processes • produce a high quality product prototype 	29–40	<p>Candidates:</p> <ul style="list-style-type: none"> • produce a good quality outcome incorporating a range of components or product design features and materials reflective of the design decisions taken during development • demonstrate a good level of competence in a range of making skills and processes • produce a good quality product prototype 	13–28	<p>Candidates:</p> <ul style="list-style-type: none"> • produce a poor quality outcome incorporating a range of components or product design features and materials reflective of the design decisions taken during development • demonstrate a basic level of competence in a range of making skills and processes • produce a poor product prototype 	1–12
AO2	<ul style="list-style-type: none"> • produce detailed evaluation of the outcome • carry out a wide range of detailed testing, showing meaningful conclusions • make detailed proposals for further development as an outcome of testing. 	7–10	<ul style="list-style-type: none"> • produce an evaluation of the outcome with some detail • carry out a good range of testing, showing some meaningful conclusions • make proposals for further development as an outcome of testing with some detail. 	4–6	<ul style="list-style-type: none"> • produce a superficial evaluation of the outcome • carry out a narrow range of testing, showing basic conclusions • make superficial proposals for further development as an outcome of testing. 	1–3
Award zero for work not worthy of credit.						

Appendix 2

Symbols

Students studying this GCE Technology and Design Specification should be familiar with the symbols below.

The symbols are presented under the following categories:

Flowchart Symbols

Electronic and Microelectronic Control symbols

Mechanical Control symbols

Pneumatic Control symbols

Flowchart Symbols

In order to avoid problems due to variations between computer control packages, only the following generic flowchart symbols will be used in examinations.

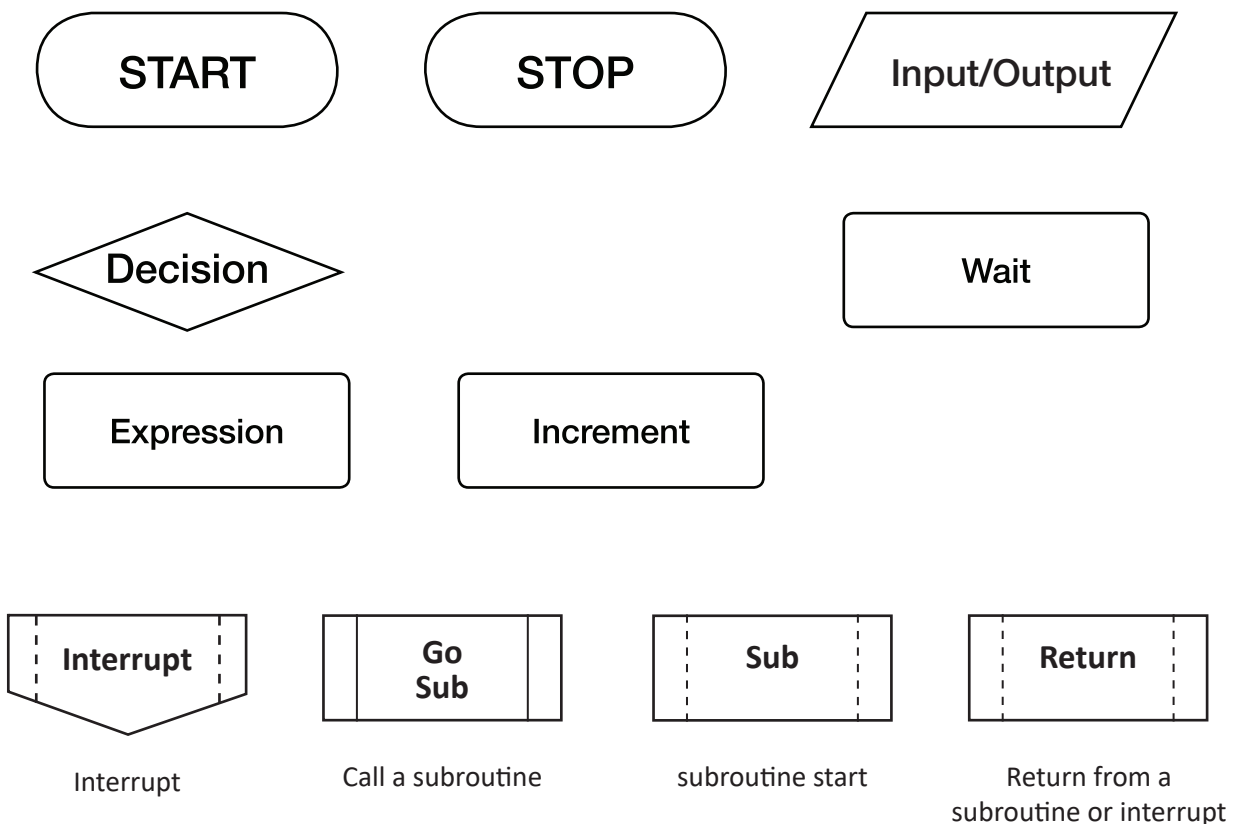

Electronic and Microelectronic Control Symbols

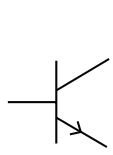

NPN transistor

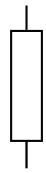

Resistor

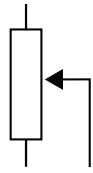

Potentiometer

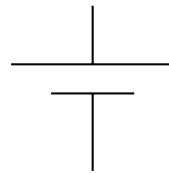

Single cell
(Battery)

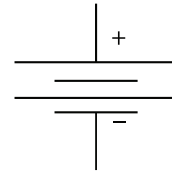

Multi cell
(Battery)

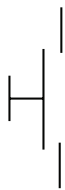

Push-to-make
switch



Reed switch

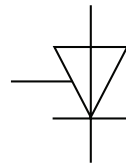

Thyristor

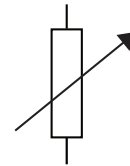

Variable
resistor



Push-to-break
switch

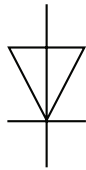

Diode



SPST switch



SPDT switch

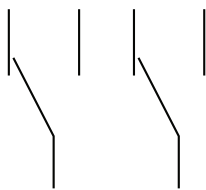

DPDT switch

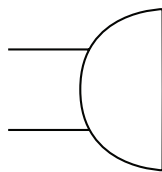

Buzzer

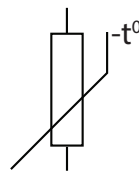

Thermistor
(negative temp
coefficient)

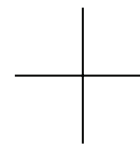

Crossing of conductors
with no electrical
connection



Terminal

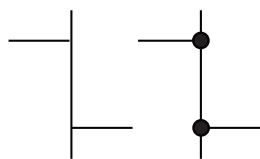

Double junction



Earth

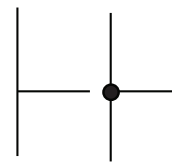

Junction of
conductors

Electronic and Microelectronic Control Symbols (cont.)

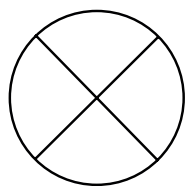

Bulb

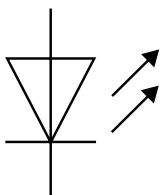

Light-emitting diode

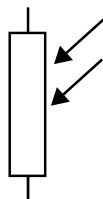

Light-dependent resistor

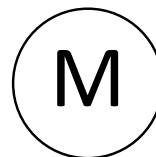

Motor

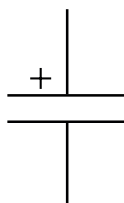

Polarised capacitor

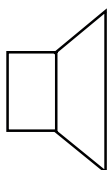

Loudspeaker



Relay make contact spring return

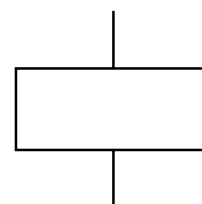

Relay coil

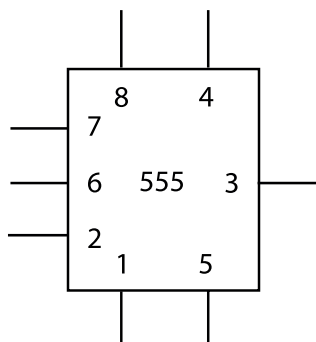

555 Timer

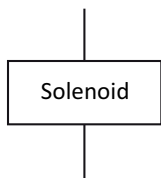

Solenoid

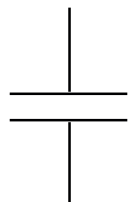

Capacitor

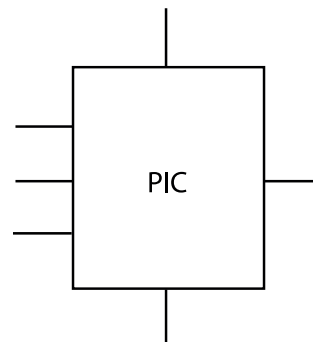

Microcontroller (PIC)

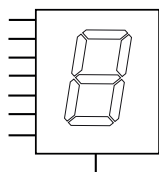

Seven Segment display common cathode

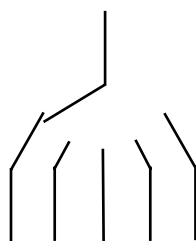

Rotary switch

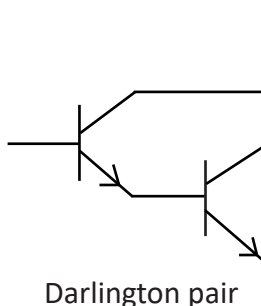

Darlington pair

Electronic and Microelectronic Control Symbols (cont.)

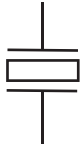

Piezo sounder



Heater

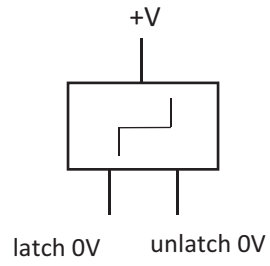

Latching relay coil

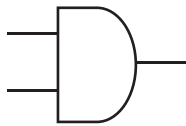

AND gate

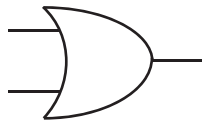

OR gate

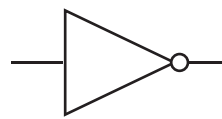

NOT gate

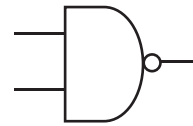

NAND gate

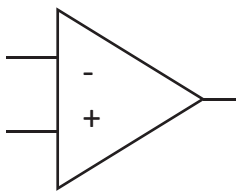

Comparator / op-amp

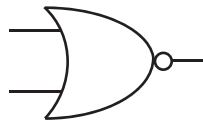

NOR gate

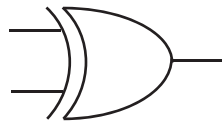

EOR gate

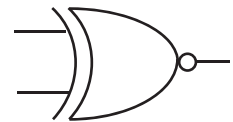

ENOR gate

Electronic and Microelectronic Control Symbols (cont.)

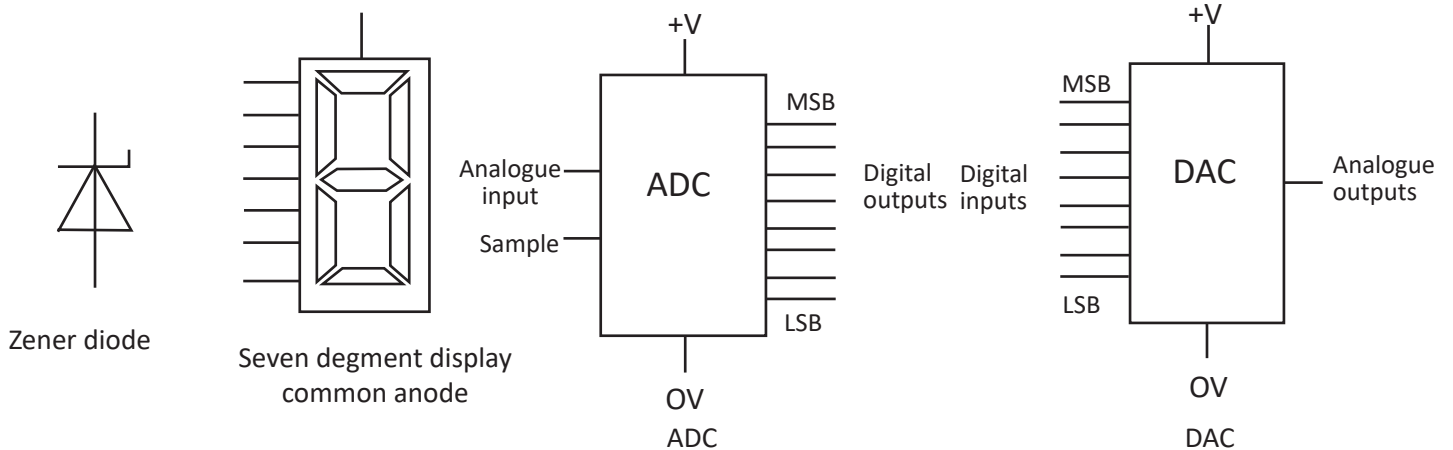
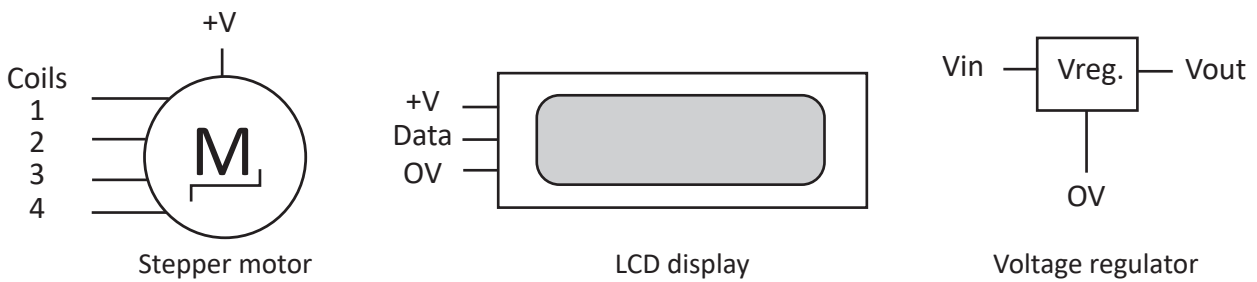
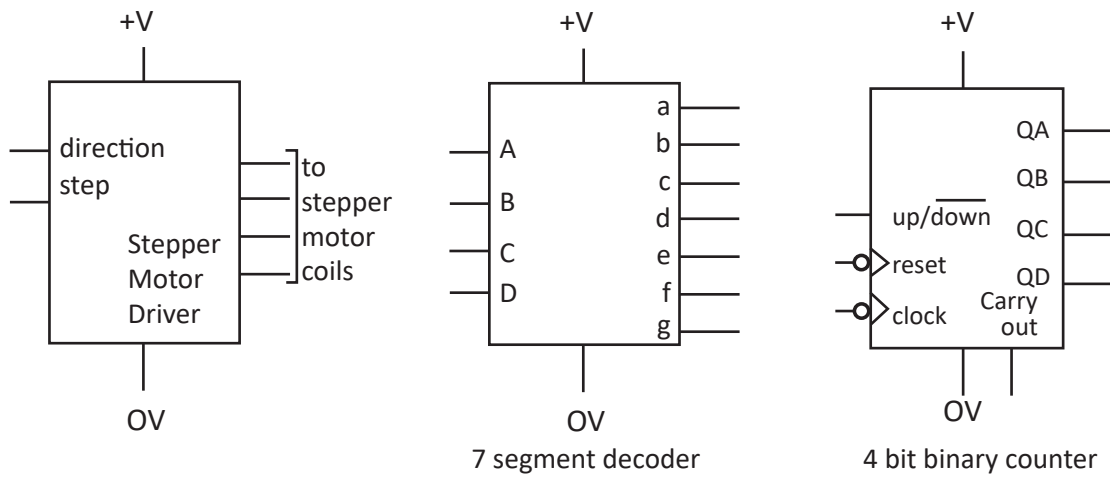
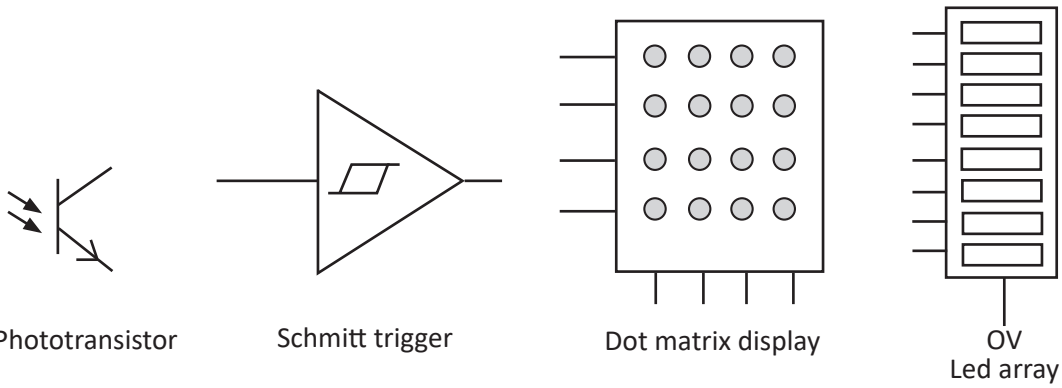

Mechanical Control Symbols

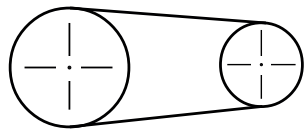

Belt and Pulley

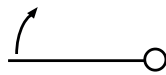

Lever

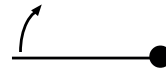

Pivoted lever

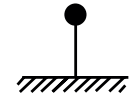

Fixed pivot

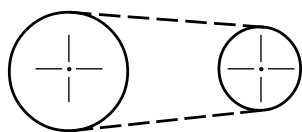

Sprocket and chain

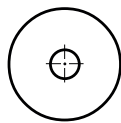

Wheel and Axle

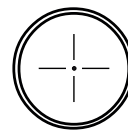

Gear

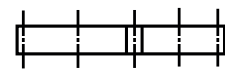

Meshed gear

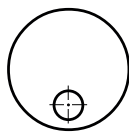

Eccentric cam

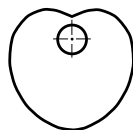

Heart-shaped cam

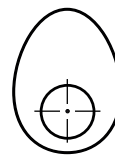

Pear-shaped cam

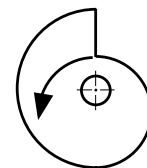

Snail cam

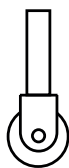

Roller follower

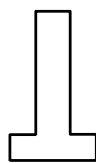

Flat follower

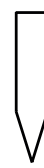

Knife follower

Mechanical Control Symbols (cont.)

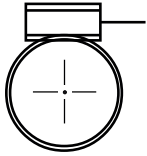

Worm and wormwheel



Jockey pulley



Fixed jockey pulley

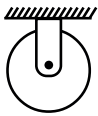

Single pulley

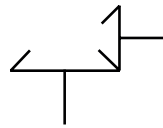

Meshed bevel gear



Bevel gear

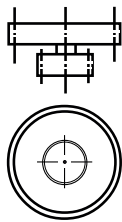

Compound gear

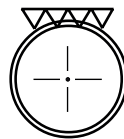

Rack and pinion

Pneumatic Control Symbols

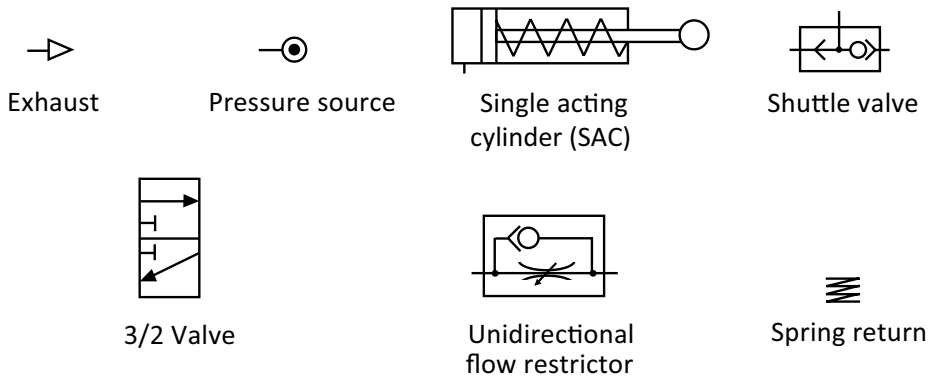

Method of Operation

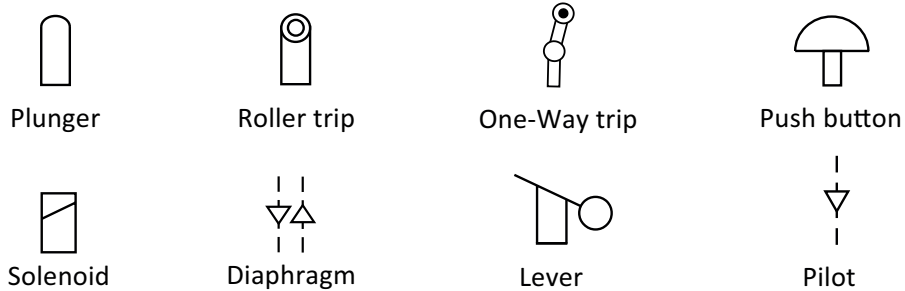

Flow Lines and Connections

Working line, return and feed line

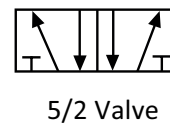
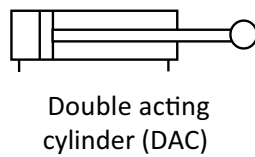
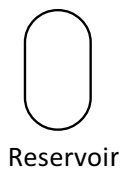
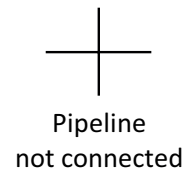
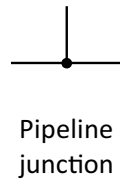
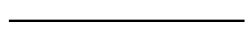

Pilot/Signal

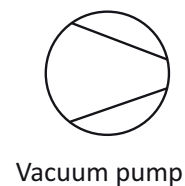
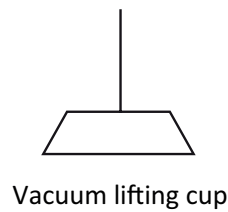
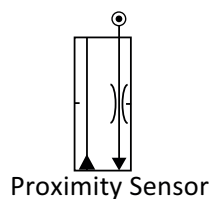
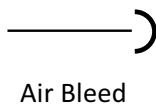
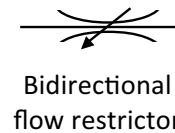
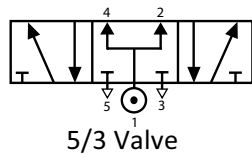

Summary of Changes since First Issue

(Most recent changes are indicated in red on the latest version)

Revision History Number	Date of Change	Page Number	Change Made
Version 1	N/A	N/A	First issue

