

Pearson Level 3 Alternative Academic Qualification
BTEC National in

Engineering (Extended Certificate)

L3

Specification

First teaching from September 2025

First certification from 2026

Issue 4

Qualification Number: 610/3962/7

Pearson Level 3 Alternative Academic Qualification BTEC National in Engineering (Extended Certificate)

Specification

First teaching September 2025

First certification from 2026

Issue 4

About Pearson

We are the world's leading learning company operating in countries all around the world. We provide content, assessment and digital services to students, educational institutions, employers, governments and other partners globally. We are committed to helping equip students with the skills they need to enhance their employability prospects and to succeed in the changing world of work. We believe that wherever learning flourishes so do people.

This specification is Issue 4. We will inform centres of any changes to this issue. The latest issue can be found on our website.

References to third party materials made in this specification are made in good faith. Pearson does not endorse, approve or accept responsibility for the content of materials, which may be subject to change, or any opinions expressed therein. (Materials may include textbooks, journals, magazines and other publications and websites.)

All information in this specification is correct at time of publication.

VQ000271

All the material in this publication is copyright
© Pearson Education Limited 2026

Welcome

BTEC Nationals are widely recognised by higher education and industry as the vocational qualification of choice at Level 3. They provide students with meaningful and practical learning experiences across a range of career sectors to prepare them to progress to higher education as a route to graduate-level employment.

Recent data has shown that one in five adults of working age in the UK has a BTEC qualification. What's more, well over 90,000 BTEC students apply to UK universities every year and their BTEC Nationals are accepted by over 150 UK universities and other higher education institutions for relevant degree programmes either on their own or in combination with A Levels.

Why are BTECs so successful?

BTECs embody a fundamentally student-centred approach to the curriculum, with a flexible, unit-based structure and knowledge applied through a balanced combination of assignments and examinations. They enable the holistic development of the practical, interpersonal and thinking skills required to succeed in higher education and employment.

When creating these BTEC Nationals we focused on the skills and personal attributes needed to navigate the future, and have worked with many higher education providers, professional bodies, colleges and schools to ensure that their needs are met. Employers are looking for future employees with a thorough grounding in the latest industry requirements and work-ready skills such as critical thinking and problem solving. Higher education needs students who have experience of research, extended writing and meeting deadlines.

We have addressed these requirements by:

- Facilitating and guiding the development of transferable skills through the design and delivery of the qualifications using a holistic and practical framework which is based on recent research into the most critical skills needed to navigate the future. This Transferable Skills framework has been used to embed transferable skills in the qualifications where they naturally occur and also to signpost opportunities for delivery and development as a part of the wider BTEC learning experience. See page 6 for further information.
- Supporting the delivery of Sustainability Education and Digital Skills development naturally through the content design of the qualifications. Mapping is provided for each qualification to identify where the opportunities for teaching and learning exist.
- Updating sector-specific content to ensure it is relevant and future-facing.
- Implementing a consistent approach to assessment with a balanced combination of internal and external assessments to better engage students, make the qualifications more accessible for them and more manageable for centres to deliver.

We are providing a wealth of support, both resources and people, to ensure that students and their teachers have the best possible experience during their course. See Section 5 for details of the support we offer.

This specification document should be used in conjunction with the [*Pearson Level 3 Alternative Academic Qualification BTEC National Specification Supplementary Information*](#) document which is available on our website.

A word to students

Today's BTEC Nationals will require commitment and hard work, as you would expect of the most respected applied learning qualification in the UK. You will have to complete a range of units, be organised, take some assessments that we will set and mark and undertake practical tasks and assignments. But you can feel proud to achieve a BTEC because, whatever your plans in life – whether you decide to study further, go on to work or an apprenticeship – your BTEC National will be your passport to success in the next stage of your life.

Good luck, and we hope you enjoy your course.

Summary of changes to Pearson Level 3 Alternative Academic Qualification BTEC National in Engineering (Extended Certificate) specification Issue 4

Summary of changes made between previous issue and this issue	Page number
Unit 1, content A1.2.1a – formula corrected	22
Unit 1, content A3.2.5 – extraneous parenthesis removed from formula	24
Unit 1, content B2.2.2, B2.2.5 and B2.3.1 – formulae corrected	27
Unit 1, content B3.1.5 – corrected from centre of pressure to average pressure	28
Unit 1, content B3.1.6a and B3.6.1b – formulae corrected	28
Unit 1, content C1.1.7a, C1.1.7b, C1.1.9a and C1.1.9b – formulae corrected	29
Unit 1, content C1.2.4 – Kirchhoff's current law corrected to Kirchhoff's voltage law	30
Unit 1, content C1.2.5 and C1.2.8a – formula corrected	30
Unit 1, content C1.2.8b – removal of duplicated formula	30
Unit 1, content C2.1.3 – removal of duplicated formula	30
Unit 1, content C2.1.5 – C2.1.7 – content numbering corrected	31
Unit 1, content C2.1.7 – removal of duplicated formula	31
Unit 1, content C2.2.1, C2.2.4 and C2.2.6c – formulae corrected	31
Unit 1, content C3.1.3d and C3.2.6 – formula corrected	32
Unit 2, content B1.2.1e – corrected spelling of 'polylactic'	44
Unit 2, content B3.5.2 – 'abrasive slitting disks' corrected to 'abrasive slitting disc'	46
Appendix 5: Formulae and Constants – corrections made to various formulae	118-126

Earlier issue(s) show(s) previous changes.

If you need further information on these changes or what they mean, please contact us via our website at: qualifications.pearson.com/en/support/contact-us.html.

Contents

1	Introduction	1
	Why choose Pearson Level 3 Alternative Academic Qualification BTEC National in Engineering (Extended Certificate)?	1
	Total Qualification Time	2
	Qualification and unit content	3
	Assessment	3
	Externally assessed units	3
	Internally assessed units	3
	Synoptic assessment	4
	Language of assessment	4
	Grading for units and qualifications	5
	UCAS tariff points	5
	Preparing students for the future	6
	Transferable skills	6
	Digital skills	6
	Sustainability Education	7
2	Qualification purpose	8
3	Structure	11
	Qualification structure	11
	Synoptic assessment	12
4	Units	13
	Understanding your units	13
	Internally assessed units	13
	Externally assessed units	15
	Index of units	17
5	Planning your programme	97
	Supporting you in planning and implementing your programme	97
	Is there a student entry requirement?	97

6	Understanding the qualification grade	98
	Awarding and reporting for the qualification	98
	Eligibility for an award	98
	Award of the qualification grade	98
	Points available for internal units	99
	Points available for external units	100
	Claiming the qualification grade	101
	Award of qualification grade	101
	Example grading table for Pearson Level 3 Alternative Academic Qualification BTEC National in Engineering (Extended Certificate)	102
	Appendix 1 Glossary of terms used for internally assessed units	103
	Appendix 2 Transferable Skills framework	105
	Appendix 3 Digital Skills framework	110
	Appendix 4 Sustainability framework	116
	Appendix 5: Formulae and Constants	118

1 Introduction

Why choose Pearson Level 3 Alternative Academic Qualification BTEC National in Engineering (Extended Certificate)?

We've listened to feedback from all parts of the engineering subject community, including higher education. We've used this opportunity of curriculum change to redesign qualifications so that they reflect the demands of a truly modern and evolving engineering environment – qualifications that enable your students to apply themselves and give them the skills to succeed in their chosen pathway.

The Pearson Level 3 Alternative Academic Qualification BTEC National in Engineering (Extended Certificate) enables students to study the principles and applications of engineering including the fundamental mechanical, electrical/electronic and mathematical principles, the engineering sectors, engineering materials, engineering processes and emerging technologies.

Students will also develop important engineering design and project management skills when developing solutions to engineering challenges/problems.

There are two examined units and two internally assessed units where students will engage in practical tasks to develop their Engineering skills and knowledge.

The qualification is designed to be taken alongside A Levels as part of a study programme and can link to learning in A Level STEM subjects such as A Level Mathematics and A Level Physics. It is intended for students that wish to progress into higher education as a pathway to employment.

Total Qualification Time

For all regulated qualifications, Pearson specifies a total number of hours that it is estimated students will require to complete and show achievement for the qualification: this is the Total Qualification Time (TQT). Within TQT, Pearson identifies the number of Guided Learning Hours (GLH) that we estimate a centre delivering the qualification might provide. Guided learning means activities, such as lessons, tutorials, online instruction, supervised study and giving feedback on performance, that directly involve teachers and assessors in teaching, supervising and invigilating students. Guided learning includes the time required for students to complete external assessment under examination or supervised conditions.

In addition to guided learning, other required learning directed by teachers or assessors will include private study, preparation for assessment and undertaking assessment when not under supervision, such as preparatory reading, revision and independent research.

BTEC Nationals have been designed around the number of hours of guided learning expected. Each unit in the qualification has a GLH value of 60, 90 or 120. There is then a total GLH value for the qualification.

Each qualification has a TQT value. This may vary within sectors and across the suite depending on the nature of the units in each qualification and the expected time for other required learning.

The following table shows the qualifications in this sector and their GLH and TQT values.

Qualification title	Size and structure	Summary purpose
Pearson Level 3 Alternative Academic Qualification BTEC National in Engineering (Extended Certificate)	360 GLH (457 TQT) Equivalent in size to one A Level. 4 mandatory units. Mandatory content (100%). External assessment (50%).	The Extended Certificate is for students who are interested in learning about the engineering sector alongside other fields of study, with a view to progressing to a wide range of higher education courses, including but not necessarily in STEM-related subjects. It is designed to be taken as part of a programme of study that includes A Levels.

Qualification and unit content

Pearson has developed the content of the new BTEC Nationals in collaboration with representatives from higher education and relevant professional bodies. In this way, we have ensured that content is up to date and that it includes the knowledge, understanding, skills and attributes required in the sector.

Centres should ensure that delivery of content is kept up to date. Some of the units within the specification may contain references to legislation, policies, regulations and organisations, which may not be applicable in the country you deliver this qualification in (if teaching outside of England), or which may have gone out-of-date during the lifespan of the specification. In these instances, it is possible to substitute such references with ones that are current and applicable in the country you deliver subject to confirmation by your Standards Verifier.

Assessment

Assessment is specifically designed to fit the purpose and objective of the qualification. It includes a range of assessment types and styles suited to vocational qualifications in the sector. There are three main forms of assessment that you need to be aware of: external, internal and synoptic.

Externally assessed units

Each external assessment for a BTEC National is linked to a specific unit. All of the units developed for external assessment are of 60, 90 or 120 GLH to allow students to demonstrate breadth and depth of achievement. Each assessment is taken under specified conditions, then marked by Pearson and a grade awarded. Students are permitted to resit the examination twice. This equates to three attempts in total: one inclusive of registration, the remaining two attempts as resits. If students resit an examined unit, the best grade achieved will count towards their overall qualification grade, not necessarily the most recent sitting. External assessments are available twice a year. For detailed information on the external assessments, please see the table in *Section 3*. For further information on preparing for external assessment, see the *Pearson Level 3 [Alternative Academic Qualification BTEC National Specification Supplementary Information](#)* document which is available on our website.

Internally assessed units

Internally assessed units are assessed by a Pearson Set Assignment Brief (PSAB), which is set by Pearson, marked by you and subject to external standards verification. Before you assess you will need to become an approved centre, if you are not one already.

You will need to prepare to assess using the guidance in the Pearson Level 3 Alternative Academic Qualification BTEC National Specification Supplementary Information document, which is available on our website: <https://qualifications.pearson.com/content/dam/pdf/BTEC-Nationals/btec-spec-supp-info.pdf>. You will make grading decisions based on the requirements and supporting guidance given in the units. Where a student has not achieved their expected level of performance for an assignment, they may be eligible for one resubmission of improved evidence for each assignment submitted if authorised by the Lead Internal Verifier. To ensure any resubmissions are fairly and consistently implemented for all students, the Lead Internal Verifier can only authorise a resubmission if certain conditions are met. If the Lead Internal Verifier does authorise a resubmission, it must be completed within 15 working days of the student receiving the results of the assessment.

Feedback to students can only be given to clarify areas where they have not achieved expected levels of performance. Students cannot receive any specific guidance or instruction about how to improve work to meet assessment criteria or be given solutions to questions or problems in the tasks.

If a student has still not achieved the targeted pass criteria following the resubmission of improved evidence for an assignment, the Lead Internal Verifier may authorise, under exceptional circumstances, one retake opportunity to meet the required pass criteria. The retake can be of a task or subset of the Pearson Set Assignment Brief that is of evidence in a new or revised form. The deadline for submission of the retake must fall within the same academic year.

Synoptic assessment

Synoptic assessment requires students to demonstrate that they can identify and use effectively, in an integrated way, an appropriate selection of skills, techniques, concepts, theories and knowledge from across the whole sector as relevant to a key task. Synoptic links between units are flagged within the units. Please refer to *Unit 3: Engineering Design* and *Unit 4: Engineering Project* for further details.

Language of assessment

Assessment of the internal and external units for these qualifications will be available in English. All student work must be in English. A student taking the qualifications may be assessed in British or Irish Sign Language where it is permitted for the purpose of reasonable adjustment.

For information on reasonable adjustments see the *Pearson Level 3 Alternative Academic Qualification BTEC National Specification Supplementary Information* document, which is available on our website.

Grading for units and qualifications

Achievement in the qualification requires a demonstration of depth of study in each unit, assured acquisition of a range of practical skills required for progression to higher education, and successful development of transferable skills. Students achieving a qualification will have completed all units.

Units are assessed using a grading scale of Distinction (D), Merit (M), Pass (P), Near Pass (N) and Unclassified (U). The grade of Near Pass is used for externally assessed units only. All mandatory and optional units contribute proportionately to the overall qualification grade, for example a unit of 120 GLH will contribute double that of a 60 GLH unit.

BTEC National qualifications are graded using a scale of P to D*, **or** PP to D*D*, **or** PPP to D*D*D* depending on the size of the qualification. Please see *Section 6* for more details. The relationship between qualification grading scales and unit grades will be subject to regular review as part of Pearson's standards monitoring processes on the basis of student performance and in consultation with key users of the qualification.

UCAS tariff points

The BTEC Nationals attract UCAS points. Please go to the UCAS website for full details of the points allocated.

Preparing students for the future

Transferable skills

Recent future skills reports have highlighted the growing importance of transferable skills for students to succeed in their careers and lives in this fast-changing world.

Following research and consultation with FE educators and higher education institutions, Pearson has developed a Transferable Skills Framework to facilitate and guide the development of transferable skills through this qualification. The Framework has four broad skill areas, each with a cluster of transferable skills as shown below:

1. **Managing Yourself:** (1) Taking personal responsibility; (2) Personal strengths and resilience; (3) Career orientation planning; (4) Personal goal setting
2. **Effective Learning:** (1) Managing own learning; (2) Continuous learning; (3) Secondary research skills (4) Primary research skills
3. **Interpersonal Skills:** (1) Written communications; (2) Verbal and non-verbal communications; (3) Teamwork; (4) Cultural and social intelligence
4. **Solving Problems:** (1) Critical thinking (2) Problem solving; (3) Creativity and innovation

Each transferable skill has a set of descriptors that outline what achievement of the skill looks like in practice. Each unit in the qualification will show whether a transferable skill has been:

1. fully embedded through the design of the teaching and learning content and assessment of the unit. Skills that are embedded are 'naturally occurring' in that they are inherent to the unit content and doesn't require extension activities to deliver.
2. signposted as an opportunity for delivery and development and would require extension activities to deliver.

Units will show a summary of the transferable skills that have been embedded or signposted and *Appendix 2* shows the descriptors for each skill across all the skill clusters.

More information on the framework, its design and relevance for student progression is available in the *BTEC Transferable Skills Guide for Teachers*. Resources and guidance to support teachers in the delivery and development of these skills will be available in the Planning and Teaching Guide for this qualification and through our training offer.

Digital skills

Digital skills are required in every industry as well as in everyday life and with the acceleration of automation and AI in industry it is critical for students to understand how digital technologies are relevant and applied in the context of the sector they are studying.

With this in mind, we have used the Digital Skills Framework published by IFATE as a frame of reference to identify opportunities for the delivery and development of digital skills in this qualification.

This Digital Skills framework has five categories with specific digital characteristics that apply in varying extent across sectors:

- **Problem Solving** – The use of digital tools to analyse and solve problems
- **Digital Collaboration and Communication** – Using digital tools to communicate and share information with stakeholders
- **Transacting Digitally** – Using digital tools to set up accounts and pay for goods/services
- **Digital Security** – Identify threats and keep digital tools safe
- **Handling Data Safely and Securely** – Follow correct procedures when handling personal and organisational data

Opportunities to develop these digital skills are identified where they are relevant and appropriate to a sector, meaning:

- where they naturally occur
- where they add no assessment burden
- where they will enhance a student's skills and knowledge in the sector.

Appendix 3 shows a mapping of the teaching and learning content to the five categories of the framework to show where opportunities to develop these digital skills exist in this qualification.

Sustainability Education

To help students develop sustainability skills, practices and mindset, we have designed content in this qualification, aligned to the [UNESCO Sustainable Development Goals](#) (17 SDGs), that are relevant and appropriate to the sector. The SDGs are the most common point of reference for content that addresses sustainability education and provides a useful and pragmatic way of presenting this content.

Sustainability knowledge and understanding may be included in the teaching and learning content but not directly assessed. Alternatively, it could be assessed – the approach chosen for each unit is based on the relevance of knowledge and understanding to the purpose and scope of the unit.

Appendix 4 shows a mapping of the teaching and learning content to the relevant SDGs to show where sustainability concepts have been included in this qualification.

2 Qualification purpose

Pearson Level 3 Alternative Academic Qualification BTEC National in Engineering (Extended Certificate)

In this section you will find information on the purpose of this qualification and how its design meets that purpose through the qualification objective and structure. We publish a full 'Statement of Purpose' for each qualification on our website. These statements are designed to guide you and potential students to make the most appropriate choice of qualification at recruitment.

Who is this qualification for?

The Pearson Level 3 Alternative Academic Qualification BTEC National in Engineering (Extended Certificate) is an Alternative Academic Qualification (AAQ) designed for post-16 students with an interest in the Engineering sector and aiming to progress to higher education as a route to graduate level employment.

Equivalent to one A Level in size, it is suitable for students looking to develop their applied knowledge and skills in Engineering as part of a study programme alongside A Levels.

What will the student study as part of this qualification?

The qualification has been developed in consultation with higher education representatives and professional bodies to ensure students have the knowledge, understanding and skills they need to progress to, and thrive in, higher education.

The qualification has four mandatory units covering the following topics:

- **Engineering Principles:** Engineering data and applying mathematical procedures in mechanical and electrical contexts
- **Engineering Applications:** Advances in modern technology and how they are reshaping the engineering sector's function; materials and processes to devise sustainable solutions to engineering problems
- **Engineering Design:** Three-dimensional (3D) models and two-dimensional (2D) detailed drawings using a computer-aided design (CAD) system
- **Engineering Project:** Project management processes in Engineering products from concept to solution.

What knowledge and skills will the student develop as part of this qualification and how might these be of use and value in further studies?

Students will develop the following knowledge and skills:

- Knowledge of units of measure, understanding of engineering data and information, application of mechanical, electronic and electrical engineering mathematical procedures in engineering contexts
- Knowledge of the engineering industry including its functional areas, emerging technologies and understanding materials and their use in the sector
- Engineering design skills including design development and technical communication skills, interpreting technical specifications and responding to briefs
- Knowledge and application of Engineering project management processes and techniques
- Transferable skills such as creativity and innovation, problem solving, personal responsibility in managing own learning and communication skills

The ability to apply mathematical and scientific principles to solve engineering problems and demonstrate critical thinking and technical communication skills in engineering contexts are key attributes needed for higher education in STEM. The experiential approach to learning, and the knowledge and skills gained will give students a solid foundation for progression and demonstrate their aptitude for STEM and meeting the demands of a range of engineering degrees.

Which subjects will complement this qualification?

The following subjects would be suitable to combine with this qualification:

- Mathematics
- Physics
- Design and Technology.

Examples of combinations within a study programme to access specific degree programmes include:

- Mathematics and Physics: progression to degrees in Engineering
- Chemistry and Mathematics: progression to degrees in Environmental Engineering or Chemical Engineering
- Design & Technology and other STEM A Level: progression to degrees in Product Design Engineering or Design Engineering.

What further learning will this qualification lead to?

This qualification can lead to progression to the following degrees:

- Mechanical Engineering BEng
- Civil Engineering BEng
- General Engineering BEng
- Electronic and Electrical Engineering BEng

Students may also progress to HNC or Foundation Degrees in Engineering.

3 Structure

Qualification structure

Pearson Level 3 Alternative Academic Qualification BTEC National in Engineering (Extended Certificate)

Mandatory units

Students must complete four mandatory units.

See *Section 6* for rules on qualification awarding.

Mandatory units – students complete all units

Unit number	Unit title	GLH	Type	How assessed
1	Engineering Principles	120	Mandatory	External
2	Engineering Applications	60	Mandatory	External
3	Engineering Design	120	Mandatory	Internal
4	Engineering Project	60	Mandatory	Internal

External assessment

50% of the total qualification GLH is made up of external assessment. A summary is given below. See the unit content and sample assessment materials for more information.

Unit	Type	Availability
Unit 1: Engineering Principles	<ul style="list-style-type: none">• An external examination set and marked by Pearson• 90 marks	January and May/June First assessment May/June 2026
Unit 2: Engineering Applications	<ul style="list-style-type: none">• An external examination set and marked by Pearson• 70 marks	January and May/June First assessment May/June 2026

Synoptic assessment

The assessment of synoptic knowledge requires students to apply learning from one unit to the assessment in another unit. There are a number of synoptic links within the qualification content. These are:

- the assessment for *Unit 3: Engineering Design*, where students will be assessed on underpinning knowledge, ideas and concepts from *Unit 1: Engineering Principles*
- the assessment for *Unit 3: Engineering Design*, where students will be assessed on underpinning knowledge, ideas and concepts from *Unit 2: Engineering Applications*
- the assessment for *Unit 4: Engineering Project*, where students will be assessed on underpinning knowledge, ideas and concepts from *Unit 1: Engineering Principles*
- the assessment for *Unit 4: Engineering Design*, where students will be assessed on underpinning knowledge, ideas and concepts from *Unit 2: Engineering Applications*.

Synoptic links are flagged within the units.

There might be some further naturally occurring synoptic opportunities across the qualification where students can synthesise their learning. These will be outlined in the Planning and Teaching Guide to help with planning for your teaching.

4 Units

Understanding your units

The units in this specification set out our expectations of assessment in a way that helps you to prepare your students for assessment. The units help you to undertake assessment and quality assurance effectively.

Each unit in the specification is set out in a similar way. There are two types of unit format:

- Internally assessed units
- Externally assessed units.

This section explains how the units work. It is important that all teachers, assessors, internal verifiers and other staff responsible for the programme review this section.

Internally assessed units

Section	Explanation
Unit number	The number is in a sequence in the sector. Numbers may not be sequential for an individual qualification.
Unit title	This is the formal title that we always use and it appears on certificates.
Unit level	All units are Level 3 on the national framework.
Unit type	This confirms that the unit is internally assessed. See structure information in <i>Section 3</i> for full details.
GLH	Units may have a Guided Learning Hours (GLH) value of 120, 90 or 60. This indicates the numbers of hours of teaching, directed activity and assessment expected. It also shows the weighting of the unit in the final qualification grade.
Unit in brief	A brief formal statement on the content of the unit that is helpful in understanding its role in the qualification. You can use this in summary documents, brochures etc.
Unit introduction	This is designed with students in mind. It indicates why the unit is important, how learning is structured and how learning might be applied when progressing to employment or higher education.
Learning aims	These help to define the scope, style and depth of learning of the unit. You can see where students should be learning standard requirements ('understand') or where they should be actively researching ('investigate'). You can find out more about the verbs we use in learning aims in <i>Appendix 1</i> .

Section	Explanation
Summary of unit	This helps teachers to see the main content areas against the learning aims and the structure of the assessment at a glance.
Content	This sets out the required teaching content of the unit. Content is compulsory except where shown as 'e.g.'. Students should be asked to complete summative assessment only after the teaching content for the unit or learning aim(s) has been covered.
Assessment criteria	Each learning aim has Pass and Merit criteria. Each assignment has at least one Distinction criterion. A full glossary of terms used is given in <i>Appendix 1</i> . Distinction criteria represent outstanding performance in the unit. Some criteria require students to draw together learning from across the learning aims.
Transferable skills	This summarises the transferable skills present within this unit. The key helps to identify whether they are signposted but require additional assessment, embedded and achieved on completion or not present in this unit.
Essential information for Pearson Set Assignment Brief (PSAB)	This shows a brief summary of the activities required for the mandatory Pearson Set Assignment Brief. Centres must download and use the mandatory PSAB without alteration or contextualisation.
Further information for teachers and assessors	This gives you information to support the implementation of assessment. It is important that this is used carefully alongside the assessment criteria and PSAB.
Resource requirements	Any specific resource requirements that you need to be able to teach and assess are listed in this section.
Essential information for assessment decisions	This information gives guidance for each learning aim or assignment of the expectations for Pass, Merit and Distinction standard. This section contains examples and essential clarification.
Links to other units	This shows you the main relationship between units. This can help you to structure your programme and make best use of materials and resources.

Externally assessed units

Section	Explanation
Unit number	The number is in a sequence in the sector. Numbers may not be sequential for an individual qualification.
Unit title	This is the formal title that we always use and it appears on certificates.
Unit level	All units are Level 3 on the national framework.
Unit type	This confirms that the unit is externally assessed. See structure information in <i>Section 3</i> for full details.
GLH	Units may have a Guided Learning Hours (GLH) value of 120, 90 or 60. This indicates the numbers of hours of teaching, directed activity and assessment expected. It also shows the weighting of the unit in the final qualification grade.
Unit in brief	A brief formal statement on the content of the unit that is helpful in understanding its role in the qualification. You can use this in summary documents, brochures etc.
Unit introduction	This is designed with students in mind. It indicates why the unit is important, how learning is structured and how learning might be applied when progressing to employment or higher education.
Summary of assessment	This sets out the type of external assessment used and the way in which it is used to assess achievement.
Assessment outcomes	These show the hierarchy of knowledge, understanding, skills and behaviours that are assessed. Includes information on how this hierarchy relates to command terms in sample assessment materials (SAMs).
Content	For external units all content is obligatory. The depth of content is indicated in the assessment outcomes and sample assessment materials (SAMs). The content will be sampled through the external assessment over time, using the variety of questions shown.
Transferable skills	This summarises the transferable skills present within this unit. The key helps to identify whether they are signposted but require additional assessment, embedded and achieved on completion or not present in this unit.
Key terms typically used in assessment	These definitions will help you analyse requirements and prepare students for assessment.
Resources	Any specific resource requirements that you need to be able to teach and assess are listed in this section.

Index of units

Unit 1: Engineering Principles	19
Unit 2: Engineering Applications	37
Unit 3: Engineering Design	51
Unit 4: Engineering Project	79

Unit 1: Engineering Principles

Level: 3

Unit type: External

Guided learning hours: 120

Unit in brief

Students will develop the skills and knowledge required to solve mechanical, electrical and electronic-based engineering problems by applying appropriate mathematical and physical science principles.

Unit introduction

Modern life depends on engineers to develop, support and control the mechanical and electrical products and systems that are all around us, for example vehicles, machinery, communication systems, computers and games consoles. To make a contribution as an engineer, you must be able to draw on an important range of principles developed by early engineering scientists, such as Newton, Watt, Faraday, Ohm and Edison.

There is an increasing demand for 'multi-skilled' engineers who can apply principles from several engineering disciplines to develop solutions to engineering problems. This unit will develop your mathematical and physical scientific knowledge and understanding to enable you to solve problems set in an engineering context. You will explore and apply the algebraic, trigonometric and calculus techniques required to solve engineering problems.

You will solve problems related to static, dynamic and fluid mechanical systems as well as static and direct current electricity, alternating current electricity and magnetism. You may apply the engineering principles you have learned to solve problems involving more than one of these topic areas.

This unit sits at the heart of the qualification and gives you a foundation to support you in your work for units 3 and 4 as well as progression to higher education.

Summary of assessment

The unit will be assessed through one examination of 90 marks lasting 2 hours 15 minutes.

Students will be assessed through a number of short open response, short- and long-calculation questions. Students will need to interpret and analyse information and diagrams related to engineering contexts and use the data presented. The questions will assess knowledge, understanding and application of mathematical, mechanical and electrical/electronic principles within contextualised problems.

The assessment availability is twice a year in January and May/June. The first assessment availability is May/June 2026.

Sample assessment materials will be available to help centres prepare students for assessment.

Assessment outcomes

AO1 Recall knowledge of units of measure

AO2 Demonstrate understanding of engineering data and information

AO3 Apply knowledge and understanding of mechanical, electronic and electrical engineering mathematical procedures in given engineering contexts

[SP-PS]

Content

The essential content is set out under content areas. Students must cover all specified content before the assessment.

There is an expectation that some lower-level mathematical techniques, for example areas of compound shapes should be within the ability of students. The formulae booklet will include these; however, in the assessment marks will not be allocated for any expected ability such as determining the area of a circle in order to make progress in a solution.

A: Algebraic, trigonometric and calculus methods

The application of these maths principles will be assessed in the context of the engineering principles in sections B and C of this unit specification. Standalone pure maths questions will not be set, however students will be expected to apply these mathematical principles in being able to solve engineering related problems.

A1 Algebraic methods

The essential content topics require students to apply knowledge to engineering problems related to sections B and C of the unit specification.

A1.1 Solve, transpose and simplify equations

A1.2 Application of the laws of indices and logarithms to engineering problems involving exponential growth and decay:

A1.2.1 laws of indices:

$$\mathbf{A1.2.1a} \quad a^m \times a^n = a^{m+n}$$

$$\mathbf{A1.2.1b} \quad \frac{a^m}{a^n} = a^{m-n}$$

$$\mathbf{A1.2.1c} \quad (a^m)^n = a^{mn}$$

A1.2.2 laws of logarithms:

$$\mathbf{A1.2.2a} \quad \log A + \log B = \log AB$$

$$\mathbf{A1.2.2b} \quad \log A^n = n \log A$$

$$\mathbf{A1.2.2c} \quad \log A - \log B = \log \frac{A}{B}$$

A1.2.3 common logarithms (base 10), natural logarithms (base e).

A1.3 Linear equations and straight line graphs to represent engineering functions and data:

A1.3.1 linear equations of the form $y = mx + c$

A1.3.2 straight-line graph (coordinates on a pair of labelled Cartesian axes, positive or negative gradient, intercept, plot of a straight line)

A1.3.3 pair of simultaneous linear equations in two unknowns

A1.4 Factorisation and quadratics:

- A1.4.1** multiply expressions in brackets by a number, symbol or by another expression in a bracket
- A1.4.2** extraction of a common factor $ax + ay, a(x + 2) + b(x + 2)$
- A1.4.3** grouping $ax - ay + bx - by$
- A1.4.4** quadratic expressions $a^2 + 2ab + b^2$
- A1.4.5** roots of an equation, including quadratic equations with real roots by factorisation, and by the use of the quadratic formula.

A2 Trigonometric methods

The essential content topics require students to apply knowledge to engineering problems related to sections B and C of the unit specification.

A2.1 Circular measure:

- A2.1.1** radian.
- A2.1.2** conversion of degree measure to radian measure and vice versa.
- A2.1.3** angular rotations (multiple number (n) of radians).
- A2.1.4** problems involving areas and angles measured in radians.
- A2.1.5** length of arc of a circle $s = r\theta$
- A2.1.6** area of a sector $A = \frac{1}{2}r^2\theta$

A2.2 Use of triangular measurement techniques to determine unknown values in engineering problems:

- A2.2.1** functions (sine, cosine and tangent)
- A2.2.2** the sine rule to solve engineering problems.
- A2.2.3** the cosine rule to solve engineering problems.
- A2.2.4** Pythagoras' Theorem.

A2.3 Application of vectors:

- A2.3.1** diagrammatic representation of vectors.
- A2.3.2** resolution of engineering quantities including velocity, force, acceleration.

A2.4 Mensuration:

- A2.4.1** standard formulae to solve surface areas and volumes of regular solids:
 - A2.4.1a** volume of a cylinder $V = \pi r^2 h$
 - A2.4.1b** total surface area of a cylinder $TSA = 2\pi r h + 2\pi r^2$
 - A2.4.1c** volume of sphere $V = \frac{4}{3} \pi r^3$
 - A2.4.1d** surface area of a sphere $SA = 4\pi r^2$

A2.4.1e volume of a cone $V = \frac{1}{3}\pi r^2 l$

A2.4.1f curved surface area of cone $CSA = \pi r l$

A3 Calculus methods

The essential content topics require students to apply knowledge to engineering problems related to sections B and C of the specification.

A3.1 Functions, rate of change and gradient of engineering functions:

A3.1.1 Function notation $y = f(x)$, $s = f(t)$, $Q = f(t)$

A3.1.2 Types of functions: polynomial, trigonometric (sine, cosine).

A3.1.3 Routine functions are differentiated in one step, using standard calculus methods and/or are not applied to an engineering context, including:

A3.1.3a polynomial

A3.1.3b trigonometric (sine, cosine)

A3.1.4 Rate of change of a function.

A3.1.5 Graphical representation of a function.

A3.1.6 Gradient of a function – graphically by tangent.

A3.2 Methods of differentiation:

A3.2.1 Gradient of a function.

A3.2.2 Small change in a quantity.

A3.2.3 Leibniz notation $\left(\frac{dy}{dx}\right)$ or representing the derivative of a function.

A3.2.4 Engineering notation for the derivative, $\left(\frac{ds}{dt}\right)$, $\left(\frac{dQ}{dt}\right)$

A3.2.5 Differentiation by standard results $y = ax^n$, where $\frac{dy}{dx} = nax^{(n-1)}$

A3.2.6 The derivatives of algebraic (powers), trigonometric (sine, cosine) functions
 ax^n , $\sin ax$, $\cos ax$

A3.3 Numerical value of a derivative:

A3.3.1 Substitution of numerical values into the expression for the derivative.

A3.3.2 Instantaneous gradient at a point on a curve.

A3.3.3 Positive, negative and zero values for gradients.

A3.3.4 Gradient values obtained analytically and graphically.

A3.3.5 Engineering examples of rates of change:

A3.3.5a velocity/acceleration of a moving object

A3.3.5b rate of charge/discharge of a capacitor

A3.3.5c charge/discharge rate for an air receiver

A3.3.5d hydraulic flow rates.

A3.4 Integration as the reverse/inverse of differentiation:

A3.4.1 Symbolic representation $\int() dx$

A3.4.2 Algebraic expressions and the constant of integration.

A3.4.3 Types of functions: polynomial, trigonometric (sine, cosine).

A3.4.4 Routine functions are integrated in one step without the need for manipulation, using standard calculus methods, including:

A3.4.4a polynomial

A3.4.4b trigonometric (sine, cosine)

A3.4.5 Integration of common functions by standard results – $ax^n, \sin ax, \cos ax$

A3.4.6 Indefinite integrals, constant of integration, initial conditions.

A3.4.7 Definite integrals – limits and square bracket notation.

A3.5 Integration as a summing tool:

A3.5.1 Area under a curve from first principles – strip theory (approximate area of the elemental strip = $y\delta x$)

A3.5.2 Area under a curve as a summation between the upper and lower limits applied to the function.

A3.5.3 Mean value and root mean square (RMS) value of periodic functions.

A3.5.4 Engineering applications

A3.5.4a work done by force producing displacement of an object

A3.5.4b distance travelled by an object

A3.5.4c mean and RMS values of waveforms in electrical circuits

A3.5.4d areas and volume.

B: Mechanical Engineering

B1 Static engineering systems

Students should be able to apply appropriate mathematical and engineering procedures and methods to complete calculations and solve problems related to static engineering systems using the correct units and showing working clearly and to an appropriate degree of accuracy.

B1.1 Static engineering systems

B1.1.1 Force $F = ma$

B1.1.2 Non-concurrent coplanar forces:

B1.1.2a representation of forces using space, vector and free body diagrams

UNIT 1: ENGINEERING PRINCIPLES

B1.1.2b moments

B1.1.2c resolution of forces in perpendicular directions
 $F_x = F \cos \theta, F_y = F \sin \theta$

B1.1.2d vector addition of forces – resultant, equilibrant and line of action

B1.1.2e conditions for static equilibrium $\sum F_x = 0, \sum F_y = 0, \sum M = 0$

B1.1.3 Simply supported beams:

B1.1.3a concentrated loads

B1.1.3b uniformly distributed loads (UDL)

B1.1.3c beams with combinations of concentrated loads and uniformly distributed loads (UDL).

B1.2 Loaded components

B1.2.1 direct stress $\sigma = \frac{F}{A}$

B1.2.2 direct strain $\varepsilon = \frac{\Delta L}{L}$

B1.2.3 shear stress $\tau = \frac{F}{A}$

B1.2.4 shear strain $\gamma = \frac{a}{b}$

B1.2.5 tensile strength.

B1.2.6 shear strength.

B1.2.7 elastic constants:

B1.2.7a Young's Modulus (modulus of elasticity) $E = \frac{\sigma}{\varepsilon}$

B1.2.7b Modulus of rigidity $G = \frac{\tau}{\gamma}$

B2 Dynamic engineering systems

Students should be able to apply appropriate mathematical and engineering procedures and methods to complete calculations and solve problems related to dynamic engineering systems using the correct units and showing working clearly and to an appropriate degree of accuracy.

B2.1 Dynamic engineering systems

B2.1.1 kinetic parameters and principles.

B2.1.2 displacement (s).

B2.1.3 velocity – initial velocity (u), final velocity (v).

B2.1.4 acceleration (a).

B2.1.5 equations for linear motion with uniform acceleration:

B2.1.5a $v = u + at$

B2.1.5b $s = ut + \frac{1}{2} at^2$

B2.1.5c $v^2 = u^2 + 2as$

B2.1.5d $s = \frac{1}{2} (u + v)t$

B2.2 Dynamic parameters and principles [SP-CT]

B2.2.1 force $F = ma$

B2.2.2 rotational inertia $I = kmr^2$

B2.2.3 torque $T = Fd$

B2.2.4 mechanical work $W = Fs$, mechanical power (average and instantaneous)

B2.2.5 mechanical efficiency $\eta = \frac{P_{out}}{P_{in}}$

B2.2.6 energy:

B2.2.6a gravitational potential energy $PE = mgh$

B2.2.6b kinetic energy $KE = \frac{1}{2} mv^2$

B2.2.7 Newton's Laws of Motion.

B2.2.8 principles of conservation of momentum.

B2.2.9 principles of conservation of energy.

B2.3 Angular parameters

B2.3.1 angular velocity (ω) $\omega = \frac{\theta}{t} = \frac{s}{rt} = \frac{v}{r}$

B2.3.2 centripetal acceleration $a = \omega^2 r = \frac{v^2}{r}$

B2.3.3 uniform circular motion power $P = T\omega$

B2.3.4 rotational kinetic energy $KE = \frac{1}{2} I\omega^2$

B2.4 Lifting machines and mechanical systems

B2.4.1 Lifting machines:

B2.4.1a inclined planes

B2.4.1b pulleys.

B2.4.2 mechanical systems

B2.4.2a gear trains

B2.4.2b chain drive systems

B2.4.3 velocity ratio $VR = \text{distance moved by effort} / \text{distance moved by load}$

$$VR = \frac{\text{driver}}{\text{driven}} = \frac{\text{distance moved by effort}}{\text{distance moved by load}}$$

B2.4.4 mechanical advantage $MA = \text{Load} / \text{effort}$

B2.4.5 friction effects $F = \mu N$

B3 Fluid engineering systems

Students should be able to apply appropriate mathematical and engineering procedures and methods to complete calculations and solve problems related to fluid engineering systems using the correct units and showing working clearly and to an appropriate degree of accuracy.

B3.1 Fluid systems

B3.1.1 density.

B3.1.2 relative density of fluids.

B3.1.3 relative density of solids.

B3.1.4 density using the floatation method.

B3.1.5 submerged surfaces in fluid systems:

B3.1.5a hydrostatic pressure on an immersed plane surface

B3.1.5b hydrostatic thrust on an immersed plane surface $F = \rho g A x$

B3.1.5c average pressure on a rectangular retaining surface with one edge in the free surface of a liquid $x = \frac{h}{2}$

B3.1.6 fluid flow in a gradually tapering pipe:

B3.1.6a volumetric flow rate $\dot{V} = Av$

B3.1.6b mass flow rate $\dot{m} = \rho Av$

B3.1.6c flow velocities (input and output)

B3.1.6d pipe diameters (input and output)

B3.1.6e cross sectional areas (input and output)

B3.1.6f incompressible fluid flow

B3.1.6g continuity of volumetric flow $A_1 v_1 = A_2 v_2$

B3.1.6h continuity of mass flow $\rho A_1 v_1 = \rho A_2 v_2$

B3.1.7 forces acting on immersed bodies:

B3.1.7a buoyant force / upthrust $F_b = \rho g V$

B3.1.7b gravitational weight.

C: Electronic and Electrical Engineering

C1 Direct current electricity and circuits

Students should be able to apply appropriate mathematical and engineering procedures and methods to complete calculations and solve problems related to electrical circuits (networks) and devices using the correct units and showing working clearly and to an appropriate degree of accuracy.

C1.1 Direct current electricity

C1.1.1 conductance.

C1.1.2 conventional current flow.

C1.1.3 charge/electron flow $I = \frac{q}{t}$

C1.1.4 voltage.

C1.1.5 Coulomb's law $F = \frac{q_1 q_2}{4\pi\epsilon_0 r^2}$

C1.1.6 factors affecting resistance, including:

C1.1.6a conductor length

C1.1.6b cross sectional area

C1.1.6c resistivity $R = \frac{\rho l}{A}$

C1.1.6d temperature coefficient of resistance, $\frac{\Delta R}{R_0} = \alpha \Delta T$

C1.1.7 resistors, including:

C1.1.7a resistors in series $R_T = R_1 + R_2 + R_3 + \dots$

C1.1.7b resistors in parallel $\frac{1}{R_T} = \frac{1}{R_1} + \frac{1}{R_2} + \frac{1}{R_3} + \dots$

C1.1.8 electric field strength, including uniform electric fields $E = \frac{F}{q}$, $E = \frac{v}{d}$

C1.1.9 capacitors:

C1.1.9a capacitors in series $\frac{1}{C_T} = \frac{1}{C_1} + \frac{1}{C_2} + \frac{1}{C_3} + \dots$

C1.1.9b capacitors in parallel $C_T = C_1 + C_2 + C_3 + \dots$

C1.1.10 factors affecting capacitance:

C1.1.10a plate spacing

C1.1.10b plate area

C1.1.10c permittivity

C1.1.10d electric flux density.

C1.1.11 relative permittivity and permittivity of free space.

C1.2 Direct current circuit theory

C1.2.1 Ohm's law $I = \frac{V}{R}, V = IR, R = \frac{V}{I}$

C1.2.2 Power $P = IV, P = I^2R, P = \frac{V^2}{R}$

C1.2.3 Efficiency $\eta = \frac{P_{out}}{P_{in}}$

C1.2.4 Kirchhoff's voltage law $V = V_1 + V_2 + V_3$ or $\sum PD = \sum IR$

C1.2.5 Kirchhoff's current law $I = I_1 + I_2 + I_3$

C1.2.6 Charge, voltage, capacitance and $Q = CV$

C1.2.7 energy stored in capacitors $W = \frac{1}{2}CV^2$

C1.2.8 RC transients (capacitor/resistor), charge and discharge:

C1.2.8a exponential growth and decay of voltage and current

$$V_c = V_s^{(-t/\tau)}$$

C1.2.8b time constant $\tau = RC$

C1.3 Direct current networks

C1.3.1 DC power sources.

C1.3.2 Resistor networks containing at least five resistors in series and parallel combinations.

C1.3.3 DC circuits containing resistors and two power sources.

C1.3.4 DC power source with at least two capacitors connected (series, parallel, combination).

C1.3.5 Electrical power.

C2 Magnetism and electromagnetic induction

Students should be able to apply appropriate mathematical and engineering procedures and methods to complete calculations and solve problems related to magnetism and electromagnetic induction using the correct units and showing working clearly and to an appropriate degree of accuracy.

C2.1 Magnetism

C2.1.1 flux density $B = \frac{\phi}{A}$

C2.1.2 magnetomotive force (mmf) $F_m = NI$

C2.1.3 permeability $\frac{B}{H} = \mu_0\mu_r$

C2.1.4 magnetic fields.

C2.1.5 magnetic field strength $H = \frac{NI}{l}$

C2.1.6 B/H curves and loops.

C2.1.7 reluctance $S = \frac{F_m}{\phi}$

C2.2 Electromagnetic induction and applications

C2.2.1 induced electromotive force (emf) $E = BLv$

$$E = -N \frac{d\phi}{dt} = -L \frac{di}{dt}$$

C2.2.2 relationship between induced emf, magnetic field strength, number of conductor turns and rate of change of flux.

C2.2.3 relationship between number of turns, magnetic length, permeability, and inductance.

C2.2.4 electrical efficiency $\eta = \frac{P_{out}}{P_{in}}$.

C2.2.5 self inductance, including:

C2.2.5a inductance of a coil $L = N \frac{\phi}{I}$

C2.2.5b energy stored in an inductor $W = \frac{1}{2}LI^2$

C2.2.6 mutual inductance (principals of transformer operation):

C2.2.6a step up/down transformers

C2.2.6b primary and secondary current and voltage ratios $\frac{V_1}{V_2} = \frac{N_1}{N_2}$

C2.2.6c efficiency $\eta = \frac{P_{out}}{P_{in}}$

C3: Single-phase alternating current

Students should be able to apply appropriate mathematical and engineering procedures and methods to complete calculations and solve problems related to single-phase alternating current using the correct units and showing working clearly and to an appropriate degree of accuracy.

C3.1 Single-phase alternating current theory

C3.1.1 waveform characteristics:

C3.1.1a amplitude

C3.1.1b time period $T = \frac{1}{f}$

C3.1.1c frequency.

UNIT 1: ENGINEERING PRINCIPLES

C3.1.2 sinusoidal and non-sinusoidal waveforms.

C3.1.3 instantaneous values:

C3.1.3a peak/peak-to-peak

C3.1.3b peak voltage

C3.1.3c form factor

$$\text{Form factor} = \frac{\text{r. m. s. value}}{\text{average value}}$$

C3.1.3d RMS voltage $V_{rms} = \frac{\text{peak voltage}}{\sqrt{2}}$

C3.1.3e average value $\text{Average value} = \frac{2}{\pi} \times \text{maximum value}$

C3.2 Single-phase alternating current principles

C3.2.1 determination of values using phasor and trigonometric representation of alternating quantities.

C3.2.2 graphical addition of two sinusoidal voltages.

C3.2.3 phasor addition of two sinusoidal voltages.

C3.2.4 reactance and impedance of pure R, L and C components

C3.2.5 total impedance of an inductor in series with a resistance $Z = \sqrt{X_L^2 + R^2}$

C3.2.6 total impedance of a capacitor in series with a resistance $Z = \sqrt{X_C^2 + R^2}$

Transferable skills

Managing Yourself	Effective Learning	Interpersonal Skills	Solving Problems
MY – TPR	EL – MOL	IS – WC	SP – CT
MY – PS&R	EL – CL	IS – V&NC	SP – PS *
MY – COP	EL – SRS	IS – T	SP – C&I
MY – PGS	EL – PRS	IS – C&SI	

Table key

*	Signposted to indicate opportunities for development as part of wider teaching and learning.
√	Embedded in teaching, learning and assessment.
Blank	TS not embedded or signposted in unit.

Key terms typically used in assessment

The following table shows the key terms that will be used consistently by Pearson in our assessments to ensure students are rewarded for demonstrating the necessary skills.

Please note: the list below will not necessarily be used in every paper/session and is provided for guidance only.

Command or term	Definition
Calculate	Students determine a value by using the information they already have and applying the relevant mathematical process. For example, 'Calculate the reaction forces...'
Prove	Students demonstrate the working of how a value is determined.
Determine	Students find or use information as part of a process to determine a fact.
Draw	Students produce a graphical representation of data by hand (as in a diagram). For example, 'Draw a diagram to represent...'
Find	Students identify the facts or truth about something by inspecting graphical information/data. For example, 'Find the coordinates where...'
Identify	Students select the correct response from given information. For example, 'Identify the unit of measure for the energy loss and identify the definition of...'
Label	Students affix a label to; mark with a label. For example, 'Label the diagram to show...'
Plot	Students mark out or allocate points on a graph

Command or term	Definition
Sketch	Students produce a graphical representation of a theoretical concept. Does not require scale.
State	Students provide a point of information

Unit 2: Engineering Applications

Level: 3

Unit type: External

Guided learning hours: 60

Unit in brief

In this unit students will explore how advances in modern technology are reshaping how a wide range of engineering sectors function. They will also explore how engineers use their understanding of materials and processes to devise sustainable solutions to engineering problems.

Unit introduction

In every aspect of our daily lives, we all depend on well-engineered safe, reliable and sustainable products and services. Across a wide range of engineering sectors, these products and services rely heavily on the technologies used in their design and delivery and the selection of appropriate materials and manufacturing processes.

In this unit, you will learn about the activities carried out in a range of engineering sectors and how these are developing in response to current technological advances. You will become familiar with a range of common engineering materials, their properties and the reasons why they might be selected in preference to alternatives for a given application. You will understand how the choice of material has a significant impact on the manufacturing process used and how both can influence the design of a component or product. You will also become familiar with a range of manufacturing processes and their applications, including modern processes such as laser cutting and additive manufacturing.

The skills, knowledge and understanding you will develop in this unit will help your progression into higher education, an apprenticeship or employment education in engineering or related discipline.

Summary of assessment

The unit will be assessed through one examination of 70 marks lasting 2 hours.

Students will be assessed through a number of multiple-choice, short- and long-answer questions. Students will need to explore and relate to contexts and data presented. The questions will assess understanding of engineering materials, processes and the impact of technological developments on a range of engineering sectors.

The assessment availability is twice a year in January and May/June. The first assessment availability is May/June 2026.

Sample assessment materials will be available to help centres prepare students for assessment.

Assessment outcomes

- AO1a** Recall knowledge of engineering sectors, functional areas and emerging technologies
- AO1bi** Recall knowledge of engineering materials
- AO1bii** Recall knowledge of engineering processes
- AO2a** Demonstrate understanding of functional areas and emerging technologies
- AO2bi** Demonstrate understanding of engineering materials
- AO2bii** Demonstrate understanding of engineering processes
- AO3a** Apply knowledge and understanding of functional areas and emerging technologies
- AO3b** Apply knowledge and understanding of engineering materials and processes
- AO4ai** Analyse the impact of emerging technologies on the functional areas of engineering organisations
- AO4aii** Analyse information to compare materials and processes
- AO4b** Evaluate information to make decisions about the selection of materials and processes in given contexts

[SP-CT]

Content

The essential content is set out under content areas. Students must cover all specified content before the assessment.

A The impact of modern and emerging technologies on functional areas across engineering sectors

Students should be aware of a range of engineering sectors, and be familiar with the engineering products and/or services they provide, the activities they carry out in the functional areas of engineering organisations and the impact of modern and emerging technologies.

A1 Engineering sectors

In addition to Mechanical Engineering and Electrical/ Electronic Engineering, students should have an awareness of a range of engineering sectors and the types of products they manufacture and/or services they carry out and/or provide. There are overlaps between the sectors in what they do, but the title of the sector indicates the main area of focus of their work.

- A1.1** Aerospace engineering, including research and development, design, manufacture, maintenance and operation of crewed aircraft, drones, satellites and spacecraft.
- A1.2** Agricultural engineering, including research and development, design, manufacture, maintenance and operation of equipment and machinery used in farming, horticulture and forestry.
- A1.3** Automotive engineering, including research and development, design, manufacture, maintenance and operation of cars, trucks, vans and motor bikes.
- A1.4** Biomedical engineering, including research and development, design and manufacture of equipment, tools and devices used in hospitals and healthcare settings.
- A1.5** Chemical engineering, including research and development, design, manufacture, maintenance and operation of plant and equipment used to make chemical products used in pharmaceuticals, food and drink, fuels and lubricants.
- A1.6** Civil engineering, including research and development, design, building and maintenance of buildings, bridges, tunnels and other infrastructure.
- A1.7** Energy generation, including research and development, design, manufacture, operation and maintenance of solar panels, wind turbines, hydroelectric systems, gas fired power stations and nuclear power stations.
- A1.8** Mechatronic engineering, including research and development, design and manufacture of electro-mechanical systems, robots, advanced sensors, instrumentation, domestic appliances, and machines.
- A1.9** Marine engineering, including research and development, design, manufacture, operation and maintenance of ships and offshore installations.

A1.10 Rail engineering, including research and development, design, manufacture, operation and maintenance of trains, rolling stock and signalling equipment.

A2 Functional areas

Students should be familiar with the activities undertaken by the functional areas of engineering organisations and be able to contextualise them for organisations operating in different sectors.

- A2.1** Research and development, including working on new technologies, products and services that will enhance competitiveness, efficiency and effectiveness for clients who use products and services.
- A2.2** Sales and marketing including market research, product promotion, product demonstration and persuading potential customers to purchase goods and services.
- A2.3** Design of engineering products and services, including using a design brief or specification to develop a product/service suitable for manufacture/delivery, creation of engineering drawings, component specifications, manufacturing instructions, process instructions, flow charts and design documentation.
- A2.4** Process monitoring and control, including monitoring the operation of manufacturing process parameters to ensure safe and efficient operation.
- A2.5** Manufacturing, including the techniques, tools and equipment used to convert raw materials and component parts into finished goods.
- A2.6** Maintenance, including equipment and process monitoring and corrective, preventative and predictive approaches to maintenance, servicing, and repair.
- A2.7** Quality management, including ensuring compliance with quality requirements and standards, planning and conducting quality control checks, maintaining quality records, analysing quality data to identify trends.
- A2.8** Energy management including the monitoring, control and conservation of energy to increase sustainability, cut usage, and minimise costs.
- A2.9** Health and safety management including risk assessment, monitoring and statutory reporting of incidents and accidents, emergency planning, training and education.
- A2.10** Information management including collaborative working, secure document storage, control and distribution.

A3 Modern and emerging technologies

Students should be familiar with modern and emerging technologies, their use, benefits and impact on the operation of functional areas in engineering organisations.

A3.1 Robotics:

A3.1.1 robots, including their use in process automation, dangerous environments, and autonomous systems

A3.1.2 cooperative robots (cobots), including their uses where robots directly assist human workers

A3.1.3 drones, including the use of unmanned aerial vehicles.

A3.2 Virtual Reality (VR), including its use to provide an immersive, simulated environment enabling collaboration and product visualisation.

A3.3 Augmented Reality (AR), including its use to enhance real world experiences with real time virtual overlays that convey information and guidance.

A3.4 Cloud computing, including its use to provide a scalable, secure and cost effective method of storing and sharing documents and data.

A3.5 Internet of Things (IoT), including its use to interconnect machines, equipment and sensors to enable monitoring, control and/or automation.

A3.6 Artificial Intelligence (AI) including its use in autonomous systems, data analysis, and vision/image recognition.

A3.7 3D printing, including its use in manufacturing, rapid prototyping and mass customisation.

A3.8 Digital twin, including its use where a virtual replica or digital representation of a physical system is used in real time monitoring, scenario simulation, monitoring and performance optimisation.

B: Materials and processes used in engineering

B1 Materials

You should be able to select and evaluate the selection of engineering materials to fulfil the performance and sustainability requirements of a given product.

B1.1 Metals

You should be familiar with the crystalline structure of metals, including the formation of grains, the effect of grain size on material properties and how solid solutions of dissimilar atoms distort the crystalline structure of metal alloys to alter material properties.

You will be familiar with the chemical symbols used for metals, the typical composition of alloys and the groups in which they belong.

B1.1.1 Pure metals:

- B1.1.1a** iron (Fe)
- B1.1.1b** copper (Cu)
- B1.1.1c** aluminium (Al)
- B1.1.1d** zinc (Zn)
- B1.1.1e** tin (Sn)
- B1.1.1f** titanium (Ti)
- B1.1.1g** lithium (Li)
- B1.1.1h** chromium (Cr)
- B1.1.1i** nickel (Ni)
- B1.1.1j** vanadium (V).

B1.1.2 Ferrous alloys:

- B1.1.2a** low carbon steel (Fe with 0.15-0.30% C)
- B1.1.2b** medium carbon steel (Fe with 0.30-0.7% C)
- B1.1.2c** high carbon steel (Fe with 0.7-1.4% C)
- B1.1.2d** cast iron (Fe with 2 – 4% C)
- B1.1.2e** austenitic stainless steel (Fe with 16-20% Cr and 6-13% Ni).

B1.1.3 Non-ferrous alloys:

- B1.1.3a** aluminium alloy (Al with 2 –10% Cu)
- B1.1.3b** titanium alloy (Ti with 5–7% Al and 3-5% V)
- B1.1.3c** brass (Cu with 35% Zn)
- B1.1.3d** bronze (Cu with 12% Sn)
- B1.1.3e** zinc alloy (Zn with 3–5% Al).

UNIT 2: ENGINEERING APPLICATIONS

B1.2 Polymers

Students should be familiar with the amorphous molecular structure of polymers, how these structures differ in thermoplastic polymers, thermoset polymers and elastomers and how these differences affect their properties.

Students should be familiar with the abbreviations used to identify polymers and the groups in which they belong.

B1.2.1 Thermoplastic polymers:

B1.2.1a polycarbonate (PC)

B1.2.1b polystyrene (PS)

B1.2.1c acrylonitrile butadiene styrene (ABS)

B1.2.1d polyethylene terephthalate (PET)

B1.2.1e polylactic acid (PLA)

B1.2.1f nylon 66 (PA66).

B1.2.2 Thermoset polymers:

B1.2.2a epoxy resin

B1.2.2b polyester resin

B1.2.2c urea formaldehyde (UF).

B1.2.3 Thermoset elastomers (TSEs):

B1.2.3a neoprene (also known as polychloroprene)

B1.2.3b silicone rubber

B1.2.3c nitrile rubber.

B1.2.4 Thermoplastic elastomers (TPEs):

B1.2.4a styrenic block copolymers (SBCs).

B1.3 Composite materials

Students should be familiar with the structures of composites and how the structures affect the mechanical properties of the material.

Students should be familiar with the abbreviations used to identify composites and the groups in which they belong.

B1.3.1 Fibre based composites:

B1.3.1a glass fibre reinforced polymer (GFRP)

B1.3.1b carbon fibre reinforced polymer (CFRP).

B1.3.2 Particle based composites:

B1.3.2a cemented carbide.

B1.3.3 The effects of matrix/reinforcement structure on the properties of composites:

B1.3.3a manipulating fibre alignment to achieve anisotropic mechanical properties in fibre based composites

B1.3.3b increasing matrix to reinforcement ratio in fibre based and particle based composites.

B2 Properties of materials

Students should be able to define and recall the units of measure and understand the important properties of the materials listed in section B1 Materials.

B2.1 Physical properties:

B2.1.1 density (kg/m^3)

B2.1.2 melting point ($^{\circ}\text{C}$)

B2.1.3 thermal conductivity (W/mK)

B2.1.4 electrical resistivity (Ωm)

B2.1.5 ferromagnetism

B2.1.6 corrosion/chemical resistance

B2.1.7 light transmission (%).

B2.2 Mechanical properties:

B2.2.1 hardness (Rockwell, Shore)

B2.2.2 impact toughness (J/m^2)

B2.2.3 elastic modulus (N/m^2 or Pa)

B2.2.4 compressive strength (N/m^2 or Pa)

B2.2.5 tensile strength (N/m^2 or Pa)

B2.2.6 ductility (elongation at failure)

B2.2.7 strength to weight ratio.

B2.3 Heat treatment of metals

Students should be familiar with heat treatment processes and their effects on grain size, crystal structure (ferrite, cementite, austenite and martensite) and mechanical properties of high carbon steels:

B2.3.1 quench hardening

B2.3.2 tempering

B2.3.3 annealing

B2.3.4 normalising

B2.3.5 case hardening of low carbon steel.

B3 Manufacturing processes

Students should be familiar with the relative benefits of each process, how it is set-up and operated, the tools and equipment required, compatible materials, the dimensional accuracy and surface finish that is achievable, speed, batch size, set-up/tooling, cost, and waste products/sustainability considerations.

B3.1 Forming:

B3.1.1 press work, including piercing and blanking out sheet metal components

B3.1.2 closed die drop forging, including the manufacture of steel forgings.

B3.2 Casting:

B3.2.1 sand casting, including the manufacture of the cast iron castings

B3.2.2 hot chamber die casting, including the manufacture of zinc alloy castings

B3.2.3 investment casting, including the manufacture of titanium castings.

B3.3 Moulding:

B3.3.1 thermoplastic injection moulding, including the manufacture of complex mouldings

B3.3.2 thermoset compression moulding, including the manufacture of complex mouldings

B3.3.3 wet lay-up, including manufacture of GFRP mouldings

B3.3.4 resin transfer moulding (RTM), including manufacture of CFRP mouldings.

B3.4 Machining:

B3.4.1 drilling, including setting up and operating for different hole sizes and workpiece material hardness.

B3.4.2 vertical milling:

B3.4.2a manual vertical milling, including common operations of milling faces, edges, shoulders and slots

B3.4.2b CNC vertical milling, including advantages over manual milling.

B3.4.3 turning:

B3.4.3a manual turning on a centre lathe, including common operations of parallel turning, facing and parting

B3.4.3b CNC turning, including advantages over manual turning.

B3.4.4 surface grinding, including use in finishing and flattening hardened steel.

B3.5 Cutting:

B3.5.1 sawing, including use of a metal cutting band saw

B3.5.2 grinding, including use of metal cutting abrasive slitting disc

B3.5.3 shearing, including use of shear press or guillotine to cut sheet metal

B3.5.4 CO2 laser, including use to cut thermoplastic sheet

B3.5.5 fibre laser, including use to cut metal sheet

B3.5.6 water jet, including use to cut metal plate

B3.5.7 electro discharge machining (EDM) or spark erosion, including its use in cutting high hardness metals:

B3.5.7a wire cutting, including use for cutting punches and dies for use in piercing and blanking press tools

B3.5.7b die sinking, including use for sinking mould cavities in injection moulding tools

B3.5.7c hole cutting, including cutting deep small diameter holes.

B3.6 Additive manufacturing (AM):

B3.6.1 Fused Deposition Modelling (FDM), including manufacture of components from PLA polymer

B3.6.2 Direct Metal Laser Sintering (DMLS), including manufacture of components from stainless steel powder

B3.6.3 Metal Fused Filament Fabrication (MFFF), including manufacture of components from stainless steel filament.

Transferable skills

Managing Yourself	Effective Learning	Interpersonal Skills	Solving Problems
MY – TPR	EL – MOL	IS – WC	SP – CT *
MY – PS&R	EL – CL	IS – V&NC	SP – PS
MY – COP	EL – SRS	IS – T	SP – C&
MY – PGS	EL – PRS	IS – C&SI	

Table key

*	Signposted to indicate opportunities for development as part of wider teaching and learning.
√	Embedded in teaching, learning and assessment.
Blank	TS not embedded or signposted in unit.

Key terms typically used in assessment

The following table shows the key terms that will be used consistently by Pearson in our assessments to ensure students are rewarded for demonstrating the necessary skills.

Please note: the list below will not necessarily be used in every paper/session and is provided for guidance only.

Command or term	Definition
Define	State or describe the nature, scope or meaning of a subject as objective facts.
Describe	Provide a clear, objective account that includes all the features/information about a subject such as a process.
Discuss	Consider in detail the different aspects of an issue, situation, problem or argument, and how they interrelate.
Evaluate	Consider various aspects of a subject's qualities in relation to its context, such as: <ul style="list-style-type: none"> • strengths versus weaknesses, • advantages versus disadvantages, • pros versus cons. Then use this information to come to a judgment supported by the evidence available.
Explain	Give a point and provide a justification.
Identify	Select the correct response from given information.
State / give / name	Provide a point of information. When applied this may be relevant to the context of a given scenario or situation.
Which of these is	Select the correct response from the given options.

Unit 3: Engineering Design

Level: 3

Unit type: Internal

Guided learning hours: 120

Unit in brief

Students will create a design solution in response to an engineering design challenge by developing three-dimensional (3D) models and two-dimensional (2D) detailed drawings including the use of a computer-aided design (CAD) system and other modelling techniques.

Unit introduction

Engineering products are part of our daily lives, from aircraft to the smallest electronic circuits found in medical devices. Engineering products are designed as a result of the identification of a need or opportunity. Engineers use creative skills and technical knowledge to devise and deliver a new design or improvements to an existing design. For example, advances in the development of battery and material technologies are leading to electric vehicles being able to travel greater distances.

In this unit, you will examine how engineers work in teams to design engineering products and understand the challenges that engineers face, such as designing out safety risks. You will learn how material properties and manufacturing processes impact on the design of an engineering product. You will use an iterative process to develop a design for an engineering product by interpreting a brief, producing initial ideas and then communicating and justifying your suggested solution. Finally, you will present your design solutions to a potential client.

Computer-aided design (CAD) spans many areas of engineering and other disciplines such as construction and media. As an engineer it is important to be able to interpret and produce engineering models and drawings that help individuals and organisations to communicate ideas, design and manufacture products and improve product performance.

Studying this unit will help you to progress to higher education and professional qualifications, either in engineering or another sector. It will also help you to progress to employment in the engineering profession or in other forms of business that communicate visually.

Learning aims

In this unit you will:

- A** Explore initial design proposals to meet the requirements of an engineering design challenge
- B** Develop initial design ideas into 3-dimensional models in response to an engineering design challenge
- C** Develop 3-dimensional models into 2-dimensional engineering drawings and present the final design solution
- D** Review the design process when responding to an engineering design challenge.

Summary of unit

Learning aim	Key content areas	Assessment approach
<p>A Explore initial design proposals to meet the requirements of an engineering design challenge.</p>	<p>A1 Interpreting product technical requirements</p> <p>A2 The characteristics and applications of materials</p> <p>A3 The characteristics and applications of manufacturing processes</p> <p>A4 Generating initial design ideas</p> <p>A5 Modelling design solutions</p>	<p>Students apply their knowledge of engineering materials and processes to synthesise a range of potential solutions that meets the requirements of the engineering design challenge.</p> <p>They explore different approaches to the solution using a range of graphical and physical modelling techniques.</p>
<p>B Develop initial design ideas into 3-dimensional models in response to an engineering design challenge</p>	<p>B1 Review of initial design ideas</p> <p>B2 CAD and 3D Parametric modelling</p> <p>B3 Developing 3-dimensional components</p> <p>B4 Developing a 3-dimensional assembled model</p>	<p>Students objectively review their initial design ideas to select a preferred idea to develop. They produce designs using 3D CAD software to refine individual elements of a design solution that combine to form a viable final solution for the engineering brief.</p>
<p>C Develop 3-dimensional models into 2-dimensional engineering drawings and present the final design solution</p>	<p>C1 Two-dimensional detailed computer-aided drawings of an engineered product</p> <p>C2 Presentation and communication skills</p>	<p>Students convert their 3D model of the final solution into orthographic drawings that present all the information needed to manufacture the solution. Students present their proposed solution to an audience explaining key features in a professional manner.</p>

Learning aim	Key content areas	Assessment approach
<p>D Review the design process when responding to an engineering design challenge</p>	<p>D1 Review of the final design solution</p> <p>D2 Reflection on personal performance</p>	<p>Students objectively review their final design solution identifying strengths and weaknesses of their approach to the design process and review their own performance highlighting their own strengths, new skills developed and areas for professional improvement.</p>

Content

The essential content is set out under content areas. Students must cover all specified content before the assessment.

Learning aim A: Explore initial design proposals to meet the requirements of an engineering design challenge

A1 Interpreting product technical requirements

Students interpret information to produce a Product Design Specification (PDS).

- Interpreting technical requirements to produce a product design specification, including:
 - user requirements
 - product functions
 - form, including:
 - aesthetics / finish
 - physical dimensions
 - weight restrictions
 - ergonomics / anthropometrics
 - potential manufacturing methods
 - potential materials
 - cost, e.g.:
 - material
 - components
 - labour
 - equipment
 - quantity
 - safety
 - maintenance
 - interactions with other areas/components
 - reliability
 - legal requirements, e.g.:
 - Intellectual property
 - Health and safety
 - Environmental legislation
 - Sustainability factors
 - refuse
 - reduce
 - reuse
 - repurpose
 - recycle.

A2 The characteristics and applications of materials

Students should be able to apply their knowledge of the properties of materials, in relation to Unit 2: Engineering Applications to suggest appropriate materials for the manufacture of a product that will fulfil the requirements of the engineering design challenge.

A3 The characteristics and applications of manufacturing processes

Students should be able to apply their knowledge of the processes applied in engineering, as specified in Unit 2: Engineering Applications to suggest appropriate methods for the manufacture of a product that will fulfil the requirements of the engineering design challenge.

A4 Generating initial design ideas

Students will apply skills to generate initial design ideas to meet customer needs for a given brief including freehand, or assistive technology design.

- Use of information:
 - responding to technical design criteria
 - researching existing products
 - checking validity of own work/findings
 - use of information sources for the solution of engineering problems:
 - manufacturers' catalogues
 - databases.
- Producing freehand design sketches:
 - 2 dimensional (2D) and 3 dimensional (3D) drawings:
 - isometric
 - oblique drawing
 - orthographic, e.g. single and linked views
 - detail drawings
 - sketching in good proportion
 - written skills using technical language.
- Generation of initial design ideas considering:
 - fitness for purpose
 - refinements
 - recognition of constraints
 - aesthetics
 - ergonomics
 - sizes
 - mechanical principles
 - material requirements
 - manufacturing processes
 - assembly arrangements

- cost estimations
- selection procedures for bought out components
- sustainability:
 - product life cycle
 - energy and resources used during production
 - waste production
 - pollution as a result of production.

A5 Modelling design solutions

Students will produce physical models to test viability of initial design ideas and aid communication with third parties.

- Using modelling materials:
 - Sheet materials, e.g.:
 - card
 - corrugated card
 - MDF (medium-density fibreboard)
 - plywood
 - acrylic.
- Casting and moulding materials, e.g.:
 - Clay
 - Polymorph™
 - Plaster.
- Modelling systems, e.g.:
 - Lego™
 - Fischertechnik™
 - Meccano™.
- Using modelling tools and awareness of commercial processes:
 - Simple hand tools to cut, shape and join modelling materials
 - 3D printing
 - Laser cutting
 - CNC machining.
- Using spreadsheets to model production costs of initial design ideas:
 - How changing design factors affects the cost of products:
 - Materials:
 - type
 - dimensions
 - waste

UNIT 3: ENGINEERING DESIGN

- Labour:
 - skilled
 - unskilled
- Equipment:
 - general purpose
 - specialist.

Learning aim B: Develop initial design ideas into 3-dimensional models in response to an engineering design challenge [IS-V&NC]

B1 Review of initial design ideas

Engineering goals in terms of performance when designing an engineering product, including:

- Design review meeting:
 - presentation of ideas to a small group of peers or others, e.g. local businesses
 - provide and receive feedback on initial design ideas through peer review.
- Consideration of the peer review feedback to select any elements that will be used to refine the 3-dimensional models.
- Selection of best idea to develop based on reasoned comparison of initial design ideas for the PDS of the engineering challenge.

B2 CAD and 3D Parametric modelling

Students will use a range of tools available within CAD software to develop a 3-dimensional model of a design idea.

- Configure the parametric modeller, including origin, units, snap and grid, correct format, project files, selection of file types and planes, e.g. XY, XZ and YZ.
- Sketching commands, including line, arc, centre line, construction line, circle, fillet, and dimension.
- Display commands, including pan, zoom, and orbit.
- Editing commands, including erase, extend, trim, and rotate.
- Construction commands, including:
 - 3D primitives, including cube, cylinder
 - 3D creation, including extrude, revolve
 - 3D modify, including hole, move face, chamfer
 - 3D Boolean, including intersect, addition, subtraction
 - 3D assembly, including place, constrain
 - 3D analysis, including stress, mass.

B3 Developing 3-dimensional components

Communication of a developed proposition to improve an engineering design idea, including:

- Creation of 2D sketches, including basic shape, dimensioning, modifications, and geometric constraints.
- 2D sketch to a 3D model, including rotate about an axis, revolve, extrude, and Boolean manipulation.
- 3D features, including:
 - threads, male and female
 - holes, including plain, drilled
 - threads, countersunk, counterbore, fillet, chamfer, rectangular or circular copy.
- Combination of solid objects, including Boolean operations.
- 2D sketching on 3D faces.
- Modification of the 3D model to improve solutions to the requirements of the engineering brief
- Analysis of the financial consequences of different material choices to include:
 - mass based on common engineering materials, e.g. aluminium and carbon steel
 - surface area of the whole or part of a component
 - volume of the whole or part of a component
 - density mass per unit volume of material.

B4 Developing a 3-dimensional assembled model

Students will combine different elements of their 3D dimensional components into an optimal solution for the engineering brief.

- Placement of 3D components, including degrees of freedom, XYZ translational freedom and XYZ rotational freedom.
- Assembly constraints and the relationships between components, including mate constraint and angle constraint assembly relationships, insert constraint and tangent constraint assembly relationships.
- Modification to 3D components due to assembly constraints.

Learning aim C: Develop 3-dimensional models into 2-dimensional engineering drawings and present the final design solution [IS-V&NC]

C1 Two-dimensional detailed computer-aided drawings of an engineered product

Students produce drawings that comply with British Standard BS 8888 or other relevant international equivalents.

- Generation of 2D drawings from a 3D model.

UNIT 3: ENGINEERING DESIGN

- Configuration of a 2D CAD system including:
 - drawing template
 - format unit
 - snap and automatic snap
 - grid
 - precision
 - angular
 - drawing limits
 - layers
 - file systems
 - scale
 - title block.
- Use of layers:
 - Manipulation
 - Creation
 - switching on/off
 - frozen
 - locked.
- Drawing commands including:
 - Line types:
 - centre line
 - dashed
 - offset.
 - hatching and editing of hatching
 - arc
 - circle
 - text
 - polyline
 - co-ordinates
 - Absolute
 - Relative
 - Polar.
- modify commands including:
 - erase
 - trim
 - mirror
 - move
 - array
 - copy

- undo
- stretch
- scale
- chamfer
- fillet.
- display commands including:
 - pan
 - zoom
 - spin.
- dimensioning
 - dimension styles
 - dimensions
 - editing of dimensions.
- component drawings including:
 - orthogonal views
 - appropriate scale
 - sectional view.
- assembly drawing including:
 - general arrangement
 - parts list or bill of materials (BOM).

C2 Presentation and communication skills

Students will communicate the outcomes of the design developments using appropriate content and methods.

- Recording documentation for presentation use.
- Convey intended meaning using different media, e.g. graphical, written, verbal.
- Context of presentation, e.g. one-to-one, group informal, formal situations.
- Use of tone and language for verbal and written communications to convey intended meaning and make a positive and constructive impact on an audience.
- Responding constructively to the contributions of others.
- Presentation, behaviour and conduct of presenter:
 - attitude
 - appropriate communication skills, e.g. to peers, business or industry audiences, ability to respond to questioning
 - preparedness.
- Negotiation and communication skills:
 - when receiving feedback on the initial design ideas
 - when analysing feedback
 - when making amendments accordingly.

Learning aim D: Review the design process when responding to an engineering design challenge [EL-CL]

D1 Review of the final design solution

Students review the outcomes of the design process.

- Design process review outcomes:
 - identifying sections/stages of the design processes where elements of the technical requirements have been achieved
 - identifying sections/stages of the design processes completed that could be improved.

D2 Reflection on personal performance

Students reflect on their own performance when completing all stages and activities of their response to the engineering challenge, design of final solutions and presentation of these solutions to others.

- Theories and frameworks for reflective practice, e.g.:
 - ERA Cycle (Experience, Reflection, Action)
 - Driscoll's What Model (What, so what, now what).
- Reviewing own performance:
 - highlighting own strengths
 - highlighting new skills developed
 - highlighting areas for professional improvement
 - reflecting on ability to stay on task and work independently.
- Performance review tools e.g. SWOT or SOAR analysis.

Assessment criteria

Learning aim A: Explore initial design proposals to meet the requirements of an engineering design challenge.

Pass	Merit	Distinction
<p>A.P1 Produce an adequate product design specification for the given engineering design challenge using some research and analysis. [SP-C&I]</p> <p>A.P2 Produce adequate initial design ideas that address some requirements of the product design specification. [SP-C&I]</p>	<p>A.M1 Produce a mostly detailed product design specification for the given engineering design challenge using detailed research and analysis.</p> <p>A.M2 Produce mostly detailed initial design ideas that address the most important requirements of the product design specification.</p>	<p>A.D1 Produce a detailed product design specification for the given engineering design challenge using comprehensive research and analysis.</p> <p>A.D2 Produce detailed initial design ideas that address most of the requirements of the product design specification.</p>

Learning aim B: Develop initial design ideas into 3-dimensional models in response to an engineering design challenge

Pass	Merit	Distinction
<p>B.P3 Review the initial design ideas and use some peer feedback to clarify the features that address some of the requirements of the product design specification. [SP-C&I]</p> <p>B.P4 Develop initial design ideas into adequate digital 3D models that address some requirements of the product design specification. [SP-C&I]</p>	<p>B.M3 Assess the initial design ideas and use peer feedback appropriately to clarify the features that address the most important requirements of the product design specification.</p> <p>B.M4 Develop initial design ideas into detailed digital 3D models that address the most important requirements of the product design specification.</p>	<p>B.D3 Evaluate the initial design ideas and use peer feedback effectively to clarify the features that address most of the requirements of the product design specification</p> <p>B.D4 Develop initial design ideas into detailed digital 3D models that address most of the requirements of the product design specification.</p>

Learning aim C: Develop 3-dimensional models into 2-dimensional engineering drawings and present the final design solution

Pass	Merit	Distinction
<p>C.P5 Develop 3-dimensional models into 2-dimensional engineering drawings to partially communicate a final design solution that meets some requirements of the product design specification, describing some decisions taken. [SP-C&I]</p>	<p>C.M5 Develop 3-dimensional models into detailed 2-dimensional engineering drawings to communicate a final design solution that meets the most important requirements of the product design specification, explaining the decisions taken.</p>	<p>C.D5 Develop 3-dimensional models into detailed 2-dimensional engineering drawings to fully communicate a final design solution that meets most of the requirements of the product design specification, justifying all decisions taken.</p>

Learning aim D: Review the design process when responding to an engineering design challenge

Pass	Merit	Distinction
<p>D.P6 Explain how the design process was used to produce a final design solution that meets some of the requirements of the product design specification.</p>	<p>D.M6 Assess how the design process was effectively used to produce a final design solution that meets the most important requirements of the product design specification.</p>	<p>D.D6 Evaluate how the design process was effectively used to produce a final design solution that meets most of the requirements of the product design specification.</p>

Transferable skills

Managing Yourself	Effective Learning	Interpersonal Skills	Solving Problems
MY – TPR	EL – MOL	IS – WC	SP – CT
MY – PS&R	EL – CL *	IS – V&NC *	SP – PS
MY – COP	EL – SRS	IS – T	SP – C&I ✓
MY – PGS	EL – PRS	IS – C&SI	

Table key

*	Signposted to indicate opportunities for development as part of wider teaching and learning.
✓	Embedded in teaching, learning and assessment.
Blank	TS not embedded or signposted in unit.

Essential information for Pearson Set Assignment Brief (PSAB)

Pearson sets the assignment brief for the assessment of this unit.

The PSAB will take 32 hours to complete.

The PSAB will be marked by centres and verified by Pearson.

The PSAB will be valid for the lifetime of this qualification.

Assessing the PSAB

You will make assessment decisions for the PSAB using the assessment criteria provided.

Section 1 gives information on PSABs and there is further information on our website.

Further information for teachers and assessors

Resource requirements

For this unit, students must have access to:

- a range of engineering data sources – for example manufacturers and supplier catalogues
- materials and equipment needed to produce initial design ideas by hand, or by using assistive technologies
- hardware and appropriate software to produce both 3-dimensional CAD models of design ideas and engineering drawings that conform to international standards
- resources to allow final design solution to be communicated to an audience.

Essential information for assessment decisions

Learning aim A

For distinction standard, students will collect and analyse a comprehensive range of primary data specific to the given engineering challenge. They will use this to refine most of the Product Design Specification (PDS) technical requirements related to user requirements, product function, form, quantity and interactions with other areas/components. For example, they will gather evidence from potential users of the product to determine their priorities for the functions the product performs.

They will collect and analyse secondary data specific to their engineering challenge that allows them to refine most of the PDS content related to potential manufacturing methods and materials, costs, safety, maintenance and reliability, legal requirements and sustainability. For example, students will fully address how they can ensure their proposed product can be designed to be sustainable.

They will use their analysis of the information to support the writing of a PDS that defines the technical requirements expected from their final design solution. They will justify most of the PDS points with reference to relevant data. Their solution to the PDS will require them to demonstrate knowledge and understanding of materials and manufacturing processes, for example that Polylactic acid (PLA) is commonly used in Fused Deposition Modelling (FDM). The PDS will support the objective evaluation of their final design solution against most of the demands of the engineering challenge.

They will produce annotated 2D and 3D sketches by freehand or using assistive technologies, in good proportion, that are detailed, technically correct and clearly convey their design intentions to a third party. For example, they will sketch linked views in an orthographic drawing that indicates the potential sizes of a component. They will produce physical models that help to convey their design intentions. Most of the requirements of the PDS will be addressed by one, or more, of these types of evidence.

UNIT 3: ENGINEERING DESIGN

They will demonstrate comprehensive analysis skills by producing written comparisons of most of their initial design ideas against the requirements of the PDS. For example, how manufacturing the product from aluminium will ease recycling, at the end of the product life cycle.

Their initial design ideas will demonstrate significantly different approaches to resolving the design challenge. For example, they will suggest machining components to form an assembly or 3D printing a single component to achieve the same outcome.

Most of their design ideas, other than those they identify as not being appropriate, will be feasible and offer effective solutions for the PDS for the engineering challenge.

For merit standard, students will collect and analyse appropriate and detailed primary data specific to the given engineering challenge. They will use this to refine the most important of the Product Design Specification (PDS) technical requirements content related to user requirements, product function, form, quantity and interactions with other areas/components. For example, they will gather photographic evidence of the environment the product will operate in.

They will collect and analyse secondary data specific to their engineering challenge that allows them to refine the most important PDS content related to potential manufacturing methods and materials, costs, safety, maintenance and reliability, legal requirements and sustainability. For example, students will determine if similar products are protected as intellectual property.

They will use their analysis of the information to support the writing of a PDS that defines the technical requirements expected from their final design solution. They will give a well-reasoned explanation of the most important PDS points with some reference to data. Their solution to the PDS will require them to demonstrate knowledge and understanding of materials and manufacturing processes, for example that fabricating steel allows complex structures to be formed. The PDS will support the objective evaluation of their final design solution against the most important demands of the engineering challenge.

They will produce annotated 2D and 3D sketches by freehand or using assistive technologies, in good proportion, that are mostly technically correct and clearly convey their design intentions to a third party. For example, they will sketch single views in an orthographic drawing that indicates the potential sizes of a component. They will produce physical models that help to convey their design intentions. The most important requirements of the PDS will be addressed by one, or more, of these types of evidence.

They will demonstrate good analysis skills by producing written comparisons of most of their initial design ideas against the requirements of the PDS. For example, how one design solution would be simpler to manufacture than another.

Their initial design ideas will demonstrate some different approaches to resolving the design challenge. For example, they will suggest a component made from polymer vacuum formed or line bent. Most of their design ideas, other than those they identify as not being appropriate, will be feasible and offer solutions for the PDS for the engineering challenge.

For pass standard, students will collect and analyse appropriate primary data specific to the given engineering challenge. They will use this to refine some of the Product Design Specification (PDS) technical requirements content related to user requirements, product function, form, quantity and interactions with other areas/components. For example, they will determine the maximum and minimum possible dimensions for their product.

They will collect and analyse secondary data specific to their engineering challenge that allows them to refine some of the PDS content related to potential manufacturing methods and materials, costs, safety, maintenance and reliability, legal requirements and sustainability. For example, students will use supplier catalogues to determine the range, and associated costs, of materials that may be appropriate to consider for the manufacture of the product.

They will use their analysis of the information to support the writing of a PDS that defines the technical requirements expected from their final design solution. They will describe most of the PDS points. Their solution to the PDS will require them to demonstrate knowledge and understanding of materials and manufacturing processes, for example that acrylic can be thermoformed. The PDS will support the objective evaluation of their final design solution against demands of the engineering challenge. Their PDS will contain sufficient detail to allow them to make a reasoned decision if their final design solution is fit for purpose.

They will produce annotated 2D and 3D sketches by freehand or using assistive technologies, in good proportion, that clearly convey their design intentions to a third party. For example, produce an isometric drawing of a component that forms part of an assembly. For example, they will sketch an isometric drawing of a component. They will produce physical models that help to convey their design intentions.

They will demonstrate good analysis skills by producing written comparisons of some their initial design ideas against the requirements of the PDS. For example how one design idea would look more appealing than another. Some of the requirements of the PDS will be addressed by one, or more, of these types of evidence.

Their initial design ideas will demonstrate some variation in approaches to resolving the design challenge. For example, they will suggest a component made from steel could be produced by bending or welding. Some of their design ideas, other than those they identify as not being appropriate, will be feasible and offer solutions for the PDS for the engineering challenge.

Learning aim B

For distinction standard, students will objectively review most of their initial design ideas against their PDS, justifying both positive and negative features they identify. For example, they will accurately calculate the cost of the materials required to manufacture a design idea and compare this to the relevant PDS requirement.

UNIT 3: ENGINEERING DESIGN

They will effectively use peer feedback and their own review, to justify why an initial idea, or combined elements of initial ideas, has been chosen to develop. For example, they will indicate that while one of their design ideas has the most positive features the same idea has a negative feature that would have a bigger influence on the success of the final product. Their responses will be logically structured and will use correct technical engineering terms with a high standard of written language, i.e. consistent use of correct grammar and spelling.

Students will produce digital 3D models of components that will form an assembly that fully meets the requirements of the engineering challenge, as detailed by the PDS.

The digital 3D models will demonstrate an iterative approach to the design process, where the features that affect the form and function of components have been investigated. For example, students will reduce the thickness of a component to improve its aesthetics while retaining its functionality.

All components of the complete final design solution will be rendered in 3D to show a realistic product design.

Students will justify their choice of materials and manufacturing processes, taking into account form and function that would be appropriate to manufacture the product. For example, they will indicate that anodising aluminium will improve its physical properties and can alter its colour.

Students will produce a 'portfolio' of images of rendered digital 3D models that show most features of the final design solution. For example, they will include different images to show an overview and zoomed in details of a component.

The format of the portfolio, for example a video recording, will be appropriate for the content they have produced. The portfolio will be logically structured and clearly present the information to a third party.

For merit standard, students will objectively review most of their initial design ideas against their PDS explaining both positive and negative features that they identify. For example, they will consider how features of their design ideas impact on the requirements of the user and compare this to the relevant PDS requirement.

They will use peer feedback, and their own review, to explain why an initial idea, or combined elements of initial ideas, has been chosen to develop. For example, they will indicate that a potential user of the product has expressed a preference.

Their responses will be logically structured, technically accurate and easy to understand.

Students will produce digital 3D models of components that will form an assembly that mostly meets the requirements of the engineering challenge, as detailed by the PDS.

The digital 3D models will demonstrate an iterative approach to the design process, where the features that affect the function of components have been investigated. For example, students will amend the sizes of components so that they will improve the way they fit together.

Most components of the complete final design solution will be rendered in 3D to show a realistic product design.

Students will explain their reasons for their choice of materials and manufacturing processes, taking into account form that would be appropriate to manufacture the product. For example, they will indicate sand casting aluminium has a low set-up cost suitable for manufacturing small numbers of products.

Students will produce a 'portfolio' of images of 3D models that mostly meet their purpose, for example to display visualisation to a potential customer, and are mostly clear for a third party to understand.

The format of the portfolio, for example a software presentation, will be appropriate for the content they have produced.

The portfolio will clearly present the information to a third party, but may lack organisation.

For pass standard, students will objectively review their initial design ideas against their PDS describing both positive and negative features they identify. For example, they will consider how features of their design ideas impact on the relevant PDS requirement.

They will use some peer feedback and their own review, to describe why elements of initial ideas have been chosen to develop. For example, they indicate why one of their design ideas will be simpler to manufacture.

Their responses may be basic in parts and may have some inaccuracies relating to engineering terminology.

Students will produce digital 3D models of components that will form an assembly that meets some of the requirements of the engineering challenge, as detailed by the PDS.

The digital 3D models will demonstrate an iterative approach to the design process, where the form of components has been investigated. For example, students will introduce curves to surface.

Some components of the complete final design solution will be rendered in 3D to show a realistic product design.

Students will explain their reasons for their choice of materials or manufacturing processes, taking into account form that would be appropriate to manufacture the product. For example, they will indicate that bonding a component will result in a better appearance than welding it.

Students should produce a 'portfolio' of images of 3D models that meet some of their purpose, for example to display visualisation to a potential customer, and present some clear information for a third party to understand.

The format of the portfolio, for example a document, will be appropriate for the content they have produced and will present the information to a third party, but may require interpretation.

Learning aim C

For distinction standard, students will use their digital 3D models developed for LA B to produce CAD orthographic drawings. These orthographic drawings may be produced manually, or by software conversion direct from the digital 3D model, or by combination of the two methods. The final digital 3D models of the solution developed for LA B will have an associated orthographic drawing produced.

All of the drawings produced will show evidence that they have prepared and used additional layers, as required by the model. For example, separate layers, with different properties, for views of the product, the drawing template, dimensions and one for annotation, will be set up.

The drawings will provide most of the information needed to allow the complete final design solution to be manufactured. For example, they will be fully dimensioned with materials specified. Overall, most details in the orthographic drawings will be produced to typically represent the standards found in BS 8888 (or other relevant standards), with very few omissions or errors evident.

Students will produce a 'portfolio' of their orthographic drawings, for example, a document that contains all the content they have produced. The portfolio will be logically structured and clearly present the information to a third party.

They will produce a report, in a format of their choice (either written or through preparation and delivery of a presentation), that describes most of the stages they have completed to produce their final design solution. The report will justify the decisions they made to arrive at their final design solution. For example, they will record why some of the initial ideas were rejected.

If students choose to prepare and deliver presentation of their report outcomes for an audience, for example their peers, the presentation should be recorded in a format that allows the content to be reviewed afterwards, for example an audio-video recording, transcript of the presentation, or a student produced script for the presentation.

When preparing the report, students will select the information they present from the evidence they have produced for all of the following elements of the Pearson-set Assignment Brief.

- the research they conducted.
- the PDS
- their initial design ideas
- why they selected an initial design idea to develop
- their digital 3D models
- their orthographic drawings
- the materials and processes that would be used to manufacture the product.

The report or presentation will be completed to a high standard that is logical, clear and consistent, and will be easily understood by non-engineers.

For merit standard, students will use their digital 3D models developed for LA B to produce CAD orthographic drawings. These orthographic drawings may be produced manually, or by software conversion direct from the digital 3D model, or by combination of the two methods.

The final digital 3D models of the solution developed for LA B will have associated orthographic drawings produced.

Most of the drawings produced will show evidence that they have prepared and used additional layers, as required by the model. For example, separate layers for views of the product, the drawing template, dimensions and one for annotation, will be set up.

The drawings will provide the most important features of the information needed to allow the complete final design solution to be manufactured. There may be some minor omissions, for example, some dimensions will not be specified. Overall, most of the details in the orthographic drawings will be produced to typically represent the standards found in BS 8888 (or other relevant standards), although there may be some minor errors evident, such as the lack of a visible gap between some features of the component and extension lines, or some text that is incorrectly orientated.

Students will produce a 'portfolio' of their orthographic drawings, for example, software presentation that contains all the content they have produced. The portfolio will clearly present the information to a third party but may lack organisation.

They will produce a report, in a format of their choice (either written or through preparation and delivery of a presentation), that describes the most important stages they have completed to produce their final design solution. The report will explain the decisions they made to arrive at their final design solution. For example, they will record why the materials specified were selected.

If students choose to prepare and deliver presentation of their report outcomes for an audience, for example their peers, the presentation should be recorded in a format that allows the content to be reviewed afterwards, for example an audio-video recording, transcript of the presentation, or a student produced script for the presentation.

When preparing the report, students will select the information they present from the evidence that have produced for all of the following elements of the Pearson-set Assignment Brief.

- the PDS
- their initial design ideas
- why they selected an initial design idea to develop
- their digital 3D models
- their orthographic drawings

The report or presentation will be completed consistently, in a clear and mostly logical way, to be understood by non-engineers.

UNIT 3: ENGINEERING DESIGN

For pass standard, students will use their digital 3D models developed for LA B to produce CAD orthographic drawings. These orthographic drawings may be produced manually, or by software conversion direct from the digital 3D model, or by combination of the two methods.

Most of the final 3D digital models developed for LA B will have associated orthographic drawings produced.

Some of the drawings will show evidence that they have prepared and used additional layers. For example, separate layers for views of the product and dimensions will be set up.

The drawings will provide some of the information needed to allow some components of the final design solution to be manufactured. There may be some minor omissions, for example some dimensions will not be specified. Overall, most details in the orthographic drawings must be suitable for a competent third party to manufacture the component.

Students will produce a 'portfolio' of their orthographic drawings that contains all the content they have produced. The portfolio will present the information to a third party, but may require interpretation.

They will produce a report, in a format of their choice (either written or through preparation and delivery of a presentation), that describes some of the stages they have completed to produce their final design solution. The report will describe the decisions they made to arrive at their final design solution. For example, they will record why they chose their initial idea to develop.

If students choose to prepare and deliver presentation of their report outcomes for an audience, for example their peers, the presentation should be recorded in a format that allows the content to be reviewed afterwards, for example an audio-video recording, transcript of the presentation, or a student produced script for the presentation.

When preparing the report, students will select the information they present from the evidence that have produced for all of the following elements of the Pearson-set Assignment Brief.

- the PDS
- their initial design ideas
- their digital 3D models
- their orthographic drawings

The report or presentation will be completed to a satisfactory standard but may have some parts that would be inaccurate or unclear.

Learning aim D

For distinction standard, students will compare their final design solution against most of the elements of their PDS. They will evaluate the extent to which they have satisfied the engineering challenge and provided an effective solution. For example, they will compare the costs they have calculated to manufacture the functions stated in the PDS.

They will identify at least three changes that could be made to their final design solution. They will then explain how these will result in improvements. For example, they may identify an alternative manufacturing process that could produce greater accuracy than the existing suggestion. All three of the changes suggested will be feasible.

Students will review how the way they worked during the production of the PDS, initial sketches, 3D models and orthographic drawings supported the success of their final design solution. They should reference a number of specific aspects in their review, i.e. how well they stayed on task and their ability to work independently, how well they demonstrated this.

Students will identify at least three ways in which their performance in the specific areas they have identified could be improved, i.e. how well they stayed on task and their ability to work independently, how well they demonstrated this. They will explain how these changes would have affected the final design solution and the presentation of the outcomes, and how their performance in the specific areas they have identified could be improved.

Students will review how effective their report (written or presentation) was in communicating their final design solution.

Overall, their submissions will be easy to read and understood by a third party, who may or may not be an engineer. They will be logically structured and use correct technical engineering terms. Students' language will be of a high standard, for example they will use correct grammar.

For merit standard, students will compare their final design solution against the most important elements of their PDS. They will assess the extent to which they have satisfied the engineering challenge and provided an effective solution. For example, they will consider how effectively they expect the product to function against the requirements stated in the PDS.

They will identify at least two changes that could be made to their final design solution. They will then explain how these changes will result in improvements. For example, they may identify how they could reduce the overall size of their product while still maintaining functionality. At least one of the changes will be feasible, and the other mostly feasible.

Students will review how the way they worked during the production of at least three of the PDS, initial sketches, 3D models and orthographic drawing stages supported the success of their final design solutions. They should reference a couple of specific aspects in their review, i.e. how well they stayed on task and their ability to work independently, how well they demonstrated this.

UNIT 3: ENGINEERING DESIGN

Students will identify at least two ways in which their performance in the specific areas they have identified could be improved, explaining how these changes would have affected the final design solution.

Students will review how effective their report (written or presentation) was in communicating their design solution.

Overall, their submissions will be easy to read and understood by a third party, who may or may not be an engineer. They will be logically structured, but may use some incorrect technical engineering terms.

For pass standard, students will compare their final design solution against some of the elements of their PDS.

They will explain the extent to which they have satisfied the engineering challenge. For example, they will describe how features of their final design solution compare to those stated in the PDS.

They will identify a change that could be made to their final design solution. They will then explain how the change will result in improvement. For example, they identify that a change in the product's appearance will mean it will be more harmonious with the environment it will function in. The change will be mostly feasible.

Students will review how the way they worked during the production of at least one of the PDS, initial sketches, 3D models and orthographic drawing stages supported the success of their final design solution. They should reference a couple of specific aspects in their review, i.e. how well they stayed on task and their ability to work independently, how well they demonstrated this.

Students will identify at least one way in which their performance in the specific areas they have identified could be improved, explaining how these changes would have affected the final design solution.

Students will review how effective their report (written or presentation) was in communicating their design solution.

Overall, their submission will be logically structured, although basic in parts.

Links to other units

This assessment for this unit allows students to draw on knowledge and understanding developed from:

Unit 1: Principles of Engineering

Unit 2: Engineering Applications.

Unit 4: Engineering Project

Level: 3

Unit type: Internal

Guided learning hours: 60

Unit in brief

Students apply project management principles to undertake an individual project and will develop conceptual or practical solutions to a chosen engineering problem related to a relevant engineering specialist area.

Unit introduction

Project management, and understanding the project life cycle, is a fundamental part of all engineering disciplines, which may involve the development of new products and services, or which may involve refurbishing or installing equipment. The output from a project is varied and could be a product/service, system or process that is relevant to your specialist area of study.

There are many approaches to project management, and in this unit, you will understand and use one project management approach to solve an engineering problem from a chosen theme or scenario. This will involve researching the engineering problem and using your creative skills to generate a range of conceptual or practical solutions to the problem. You will produce a feasibility study to select the most appropriate solution taking into consideration any given constraints. You will make use of project management processes, such as planning and monitoring progress, to design and develop a solution that is fit for purpose. A key skill of professional engineers is to be an effective communicator so that complex technical information can be conveyed.

You will demonstrate communication skills and high standards of behaviour during the development of your solution before showcasing your ideas in an accurate technical portfolio.

The purpose of the applied engineering project is for you to research and develop project solutions that are specific to your area of interest in engineering. The project will allow you to explore the modern engineering world such as factory automation, for example robots/cobots, wearable technology, industrial use of drones, Virtual Reality (VR), Augmented Reality (AR), Internet of Things (IoT), additive manufacturing or sustainability. Your project could be purely research based and deliver conceptual solutions, or it could involve the manufacture of a prototype product, or it could involve the analysis and use of data such as Statistical Process Control (SPC) to meet the requirements of the chosen project.

The completion of this unit will help you to progress to higher education.

Learning aims

In this unit you will:

- A** Investigate an engineering project in a relevant specialist area
- B** Develop project management processes and a design solution for the engineering project
- C** Undertake the solution for an engineering project and develop skills to present the solution

Summary of unit

Learning aim	Key content areas	Assessment approach
<p>A Investigate an engineering project in a relevant specialist area</p>	<p>A1 Project life cycle</p> <p>A2 Project idea generation and solution development</p> <p>A3 Feasibility study of solutions</p>	<p>Students investigate an initial idea and possible solutions, scoping out alternative technical solutions and complete a feasibility study report of the possible solutions.</p>
<p>B Develop project management processes and a design solution for the engineering project</p>	<p>B1 Planning and monitoring project management processes</p> <p>B2 Risk and issue project management processes</p> <p>B3 Technical specification</p> <p>B4 Design information</p>	<p>Students apply project management processes, such as planning during the design of a solution and develop a technical specification that may include design documentation, such as orthographic projections of the chosen solution.</p>
<p>C Undertake the solution for an engineering project and present the solution</p>	<p>C1 Undertake and test the solution to the problem</p> <p>C2 Demonstrate relevant behaviours</p> <p>C3 Present a solution to the problem</p>	<p>Students apply project management processes, such as project monitoring, and apply relevant behaviours during the development and testing of a solution. Students review the processes and reflect on own performance while completing the applied project.</p>

Content

The essential content is set out under content areas. Students must cover all specified content before the assessment.

Learning aim A: Investigate an engineering project in a relevant specialist area

A1 Project life cycle

The essential content topics require students to apply knowledge of the following four stages of a project life cycle:

- initiation, to include identifying a problem, research and clarification of a problem, establishing key features of the problem, possible solutions and constraints, idea generation and a feasibility study.
- planning and design, to include resource and time planning for the chosen solution and creating a design based on the technical requirements.
- implementation, to include undertaking project processes to develop the solution while controlling the project by monitoring it against the plans and managing risks and issues.
- evaluation, to include reviewing the outcome of the project including whether the technical requirements were met and how the project was delivered to the given theme or specification.

A2 Project idea generation and solution development

The essential content topics require students to apply knowledge when identifying a suitable problem, perhaps based on a theme, and creation of alternative solutions, these include:

- investigating the given project theme and identifying problems to be solved using relevant resources, e.g. the internet, journals, databases, libraries, publicly available company information.
- researching creativity tools to solve problems, including rewording problems, challenging assumptions, thinking in reverse, mind mapping, drawing a diagram, group discussion, brainstorming and Edward De Bono's Six Thinking Hats®.
- a specification that scopes out alternative technical solutions, using outline information to define what is possible, as yet undesigned, products, systems or processes are intended to contain and do. The specification could include:
 - graphic solutions, e.g. sketches, diagrams, photographs and storyboards
 - an outline of the required processes, e.g. machine tools, systems, assemblies, high-level flow chart
 - an outline of costings, e.g. spreadsheet, material cost, budgets
 - initial technical information, e.g. approximate mass, approximate volume, suggested materials, outline performance parameters.

A3 Feasibility study of solutions

The essential content topics require students to apply knowledge, including:

- criteria to determine the feasibility of different solutions to a problem, including the potential:
 - size and complexity of the problem to be solved
 - size of the benefit and performance improvement, including how well a solution solves a problem
 - cost and time required to develop each solution, available time, available budget
 - expertise required to develop a solution
 - risks in developing a solution, e.g. unknowns, unproven technology, equipment, time and cost
 - sustainability, e.g. environmental impact of mass production, waste material, choice of materials, recycling
 - legal constraints, e.g. the current data protection legislation, Health and Safety at Work legislation or other relevant international legislation.
- selection of the proposed solution:
 - objective testing
 - design analysis, including iterative steps, feasibility assessment, cost-benefit
 - comparison methods:
 - statistical/graphical e.g. frequency table, histogram, frequency distribution, bar chart, pie chart
 - quality and resource requirements/limitations
 - process capability
 - fitness-for-purpose.

Learning aim B: Develop project management processes and a design solution for the engineering project [MY-TPR]

B1 Planning and monitoring project management processes

The essential content topics require students to apply knowledge, understanding and skills including:

- resource planning/resources required for the project, to include the internet, personnel, peers, books and equipment.
- time planning, to include a Gantt chart and critical path analysis to set priorities for different activities.
- project contingency, e.g. an amount of time or additional budget that is included in the plan to manage unforeseen events.
- project constraints, including time, budget, scope, sustainability, ethics and legality.

UNIT 4: ENGINEERING PROJECT

- scheduled and frequent monitoring and management of the project, including:
 - logbook of problems and solutions, technical support, progress, discussions, group activities and development iterations
 - progress against the plan, project milestones, modifications
 - teacher monitoring, peer reviews.

B2 Risk and issue project management processes

The essential content topics require students to apply knowledge, understanding and skills including:

- the purpose of risk and issue management:
 - avoiding 'crisis management'
 - improving the probability of success and increasing competitive advantage.
- a risk is an event that adversely impacts on the project processes or outcome, and an issue is a future event which could adversely or positively impact project processes or outcome.
- risk and issue measures, including:
 - risk and issue severity = low, medium, high and extreme
 - probability of occurrence = unlikely, likely and very likely
 - expected project impact = minor, moderate and major.
- the risk or issue severity = probability of the occurrence × expected impact on the project, e.g. on the customer's requirements, delivery to schedule and to budget.
- the need to assess risks and issues throughout the delivery of the project where medium, high and extreme severity risks and issues should be managed.
- management of risks and issues (mitigation), including:
 - prevention (to eliminate the threat of a risk occurring)
 - reduction (to reduce the likelihood of a risk occurring or to reduce the impact of a risk or issue)
 - acceptance (to do nothing about a risk or issue) or transference (to transfer the risk to a third party).
- allowing contingency in the plans provides some flexibility in the event that risks and issues occur.

B3 Technical specification

Technical specification for the chosen solution being developed, e.g. function and features, interfaces (physical, software, human and electrical/electronic), materials, tolerances, standards, security, environmental considerations and sustainability, operational conditions, process capability, reliability, capacity (current and future), maintenance and performance.

B4 Design information

The essential content topics require students to apply knowledge, understanding and skills including:

- tools used to design the solution:
 - engineering drawings/orthographic projections, computer-aided design (CAD), e.g. 3D, 2D and diagrams
 - simulations, e.g. pneumatic circuits, hydraulic circuits, electrical/electronic circuits and software models
 - physical modelling, e.g. 3D rapid prototyping (also known as 3D printing or additive manufacturing), mock-ups in wood, cardboard and modelling material
 - processes or computer program, e.g. detailed flow chart(s), planning, operation sheets
 - types of documents used when designing solutions, e.g. reference charts/tables, formulae, pseudocode, outline of key algorithms, description and record of ergonomic analysis
 - safety and sustainability considerations, including:
 - regulations including, health and safety legislation relevant to the specialist engineering area
 - demand and costs, e.g. possible demand, material costs, manufacturing costs
 - culture, e.g. beliefs, laws, customs.
- test plans to relevant British Standard (BS) or International Standard (IS) where appropriate, e.g. destructive and non-destructive test inspection methods and data (normal, extreme and erroneous).

Learning aim C: Undertake the solution for an engineering project and present the solution [MY-TPR]

C1 Undertake and test the solution to the problem

Undertake and test the final solution against the technical specification, including:

- the use of project management processes during the development of a solution, to include status reporting and management of risks and issues.
- the safe use of resources, e.g. machines, workshops, tools and consumables.
- troubleshooting methods to resolve problems, e.g. expected behaviour, half-split, cause and effect, 5 Whys.
- fitness for purpose, e.g. quality, usability, functionality, performance, compliance to customer requirements (see technical specification).
- testing methods e.g. destructive, non-destructive, inspection, measurement.
- types of test data e.g. discrete data, continuous data, ungrouped data, grouped data.
- test data analysis, visual presentation of test data analysis e.g. line graphs, bar charts, scatter diagrams, pie charts, histograms, distribution curve, Venn diagram tables, mean, mode, median.

C2 Demonstrate relevant behaviours

Relevant behaviours include:

- time planning and management to complete all the different activities within an appropriate timeframe and in an appropriate order.
- communication and literacy skills to follow and implement instructions appropriately, interpret documentation and communicate effectively with others verbally and in writing.
- commercial and customer awareness to ensure the product/service, process or system is fit for purpose and meets the brief.
- observable emotions linked to successes and issues during the project development, including personal successes and issues as well as attitudes and behaviour, demonstration of resilience and adaptability, response to constructive criticism.
- individual support required to complete the project, e.g. practical support, academic support, external support.

C3 Present a solution to the problem

Collation of a project portfolio including:

- thematic title and/or initial idea.
- research and clarification of the problem.
- possible solutions and constraints.
- initial specification of alternative technical solutions.
- feasibility study.
- technical specification.
- project management documents, including plans and a risk and issues log.
- logbook of events, e.g. diary, outline sketches, notes, records.
- design documents, e.g. sketches, engineering drawings, simulation and flow charts.
- artefacts for a product/service, process or system, e.g. prototype product, computer program, pneumatic or hydraulic circuit, electronic circuit, experiment process demonstration.
- test documentation, e.g. results of test data analysis, video, customer feedback and photographs.
- peer reviews and tutor monitoring.
- conclusions on the success of the solution against the project theme and initial idea.

Assessment criteria

Learning aim A: Investigate an engineering project in a relevant specialist area

Pass	Merit	Distinction
<p>A.P1 Explain, using some technical terms, at least three solutions to an engineering problem and select a preferred solution that partially addresses the researched problem.</p>	<p>A.M1 Assess, using suitable technical language, at least three solutions to an engineering problem on a chosen theme and recommend a preferred solution that mostly addresses the researched problem. [SP-PS]</p>	<p>A.D1 Evaluate, using language that is technically correct and of a high standard throughout, realistic solutions to an engineering problem on a chosen theme and justify a preferred solution that fully addresses the researched problem.</p>

Learning aim B: Develop project management processes and a design solution for the engineering project

Pass	Merit	Distinction
<p>B.P2 Implement some appropriate project management planning and monitoring processes.</p> <p>B.P3 Produce an adequate technical specification for a solution to the engineering problem that covers aspects of the chosen solution with some gaps.</p> <p>[SP-C&I]</p> <p>B.P4 Produce design documentation to detail the solution taking account of some aspects of sustainability. [SP-C&I]</p>	<p>B.M2 Implement mostly appropriate project management planning and monitoring processes.</p> <p>B.M3 Design a coherent solution, that covers most aspects of the chosen solution, considering alternative approaches and sustainability.</p>	<p>B.D2 Optimise fully appropriate project management planning and monitoring processes and the design solution while allowing for reasonable contingency and full consideration of sustainability.</p>

Learning aim C: Undertake the solution for an engineering project and present the solution

Pass	Merit	Distinction
<p>C.P5 Produce a partially appropriate solution safely, using appropriate project management planning and monitoring processes.</p> <p>C.P6 Demonstrate some appropriate behaviours while developing a solution safely.</p>	<p>C.M4 Produce an appropriate solution that is mostly fit for purpose, using mostly appropriate project management planning and monitoring processes while justifying refinements and demonstrating appropriate behaviours. [SP-PS]</p>	<p>C.D3 Optimise a solution that is fit for purpose, using fully appropriate project management planning and monitoring processes, demonstrating effective and consistent behaviours.</p>

Transferable skills

Managing Yourself	Effective Learning	Interpersonal Skills	Solving Problems
MY – TPR *	EL – MOL	IS – WC	SP – CT
MY – PS&R	EL – CL	IS – V&NC	SP – PS √
MY – COP	EL – SRS	IS – T	SP – C&I √
MY – PGS	EL – PRS	IS – C&SI	

Table key

*	Signposted to indicate opportunities for development as part of wider teaching and learning.
√	Embedded in teaching, learning and assessment.
Blank	TS not embedded or signposted in unit.

Essential information for Pearson-set Assignment Brief (PSAB)

Pearson sets the assignment for the assessment of this unit.

The PSAB will take 30 hours to complete.

The PSAB will be marked by centres and verified by Pearson.

The PSAB will be valid for the lifetime of this qualification.

Assessing the PSAB

You will make assessment decisions for the PSAB using the assessment criteria provided.

Section 1 gives information on PSABs and there is further information on our website.

Further information for teachers and assessors

Resource requirements

For this unit, students must have access to a variety of physical resources, specialist software and databases.

Essential information for assessment decisions

Learning aim A

For distinction standard, students will produce research evidence containing at least three possible solutions to the given theme. The research evidence and alternative solutions to an engineering problem will be realistic, accurate and concise. For example, a project to design and manufacture a jig to hold a component whilst conducting manufacturing operations could involve researching computer-aided design (CAD) and different additive manufacturing processes, as well as producing a model of the jig using an appropriate additive manufacturing process. Students will provide outline sketches, possible processes, outline costs and other technical information. The evaluation of initial solutions will be fully supported by research applied consistently across each solution. A range of technical criteria will allow good justification for the preferred solution to be presented. For example, the outline sketches and specification of the jig will be assessed against the suitability, in terms of size and capability and availability of different additive manufacturing processes at the centre. Costs of using different processes would also be calculated and compared. Overall, the evidence, including the research and feasibility study that will evaluate the three solutions and will be easy to read and understood by a third party who may or may not be an engineer. It will be logically structured and use correct technical engineering terms. Consideration will also be given to the number of possible design iterations required while developing the solution.

For merit standard, students will produce research evidence covering at least three possible solutions to an engineering problem. All solutions will be investigated consistently (to a similar breadth and depth) but one solution may not be realistic. The feasibility study will assess each of the three solutions in turn. The study will be supported by research evidence of consistent breadth and depth across the three solutions. Sufficient technical criteria will be used in the assessment to make an informed rationale for the preferred solution. For example, the manufacturing costs (including materials and tooling) for the jig designs will be estimated and compared. Overall, the evidence will be logically structured, technically accurate, and use suitable technical language that is easy to understand.

For pass standard, students will produce research evidence covering at least three possible solutions to an engineering problem. The research will be patchy in some areas and it may not support all the solutions given. At least one solution may not be realistic. For example, the materials used to produce the jig may not be totally appropriate as consideration has not been given to the required stiffness of the jig to hold the component securely in the desired position. The feasibility study will explain each of the three solutions in turn. The study will be supported by the research although the depth of evidence will be inconsistent across the three solutions and the study will not cover enough criteria to make an informed decision on which solution to develop. A preferred solution will be selected. For example, the student will have taken into consideration the suitability of different materials and the capability of some additive manufacturing machines but will not have estimated the costs. Overall, the evidence will be logically structured, although basic in parts, and may contain minor technical inaccuracies relating to engineering terminology.

Learning aim B

For distinction standard, students will produce an optimised project time and resource plan, outlining the critical path and suitable milestones and breaking down the activities in an appropriate way given the constraints, allowing a reasonable contingency. Most time and resource estimates will be reasonable and consideration will be given to optimising the plan so that it can be implemented in an efficient and effective way. Throughout the project, progress will be monitored, and risks and issues managed by anticipating some problems before they become issues, and categorising risks and issues appropriately. The technical specification will detail the requirements that link together to create a functioning and coherent solution given the known technical criteria. For example, the jig will be manufactured using an additive manufacturing process and details of the materials, infill, layer orientation, layer height and working tolerances such as hole dimensions will be provided to an international standard. The design evidence, which may be included in the technical specification, will provide details of the proposed solution and appropriate tools will be used given the nature of the engineering theme given to the student in the PSAB. The design evidence will consider sustainability and contain appropriate detail. The solution will be optimised by iteration, within given constraints, by considering the merits of alternative approaches to achieving the chosen solution. For example, the orientation, layer height and infill parameters of the additive manufacturing process will be optimised to provide the required structural rigidity whilst keeping printing time to a minimum. Overall, the evidence will be logically structured, technically accurate and easy to understand by a third party who may or may not be an engineer.

For merit standard, students will produce a detailed project time and resource plan, outlining the critical path and suitable milestones and breaking down the activities in an appropriate way. Most time and resource estimates will be reasonable. For example, the estimated start and finish times to produce CAD drawings and use of additive manufacturing machines to produce the jig will be realistic. Project monitoring documentation will also be prepared. Risk and issue management processes will be set up and major risks and issues will be recorded and proactively managed with effective mitigation to prevent some major risks becoming issues. The technical specification will detail the requirements that link together to create a functioning and coherent solution. For example, the size of the jig will be necessary to meet the customer requirements, whilst taking into consideration the limitations of the additive manufacturing process. The design evidence, which may be included in the technical specification, will provide details of the proposed solution and appropriate tools will be used given the nature of the product/service, system or process. The design evidence will consider sustainability and contain appropriate detail while considering the merits of alternative approaches to achieving the chosen solution. For example, an alternative method of manufacturing the jig would be fabrication instead of additive manufacturing.

For pass standard, students will produce evidence containing a project time and resource plan outlining the critical path. The plan will be sufficiently detailed to track the project, although some tasks may be omitted and the time and resource estimates for several tasks may be extreme, making them unrealistic. For example, the time estimated to produce the CAD drawings for the jig may be specified as a couple of hours when a realistic estimate would be two days to complete and edit the drawings. Risk and issue management processes will be set up and major risks and issues will be recorded, although actions taken to prevent risks becoming issues are unlikely to be implemented and/or the mitigating actions will not be successful. The technical specification will outline requirements that may not link together to create a functioning and coherent solution. For example, the manufacture of the jig may include the additive manufacturing process that will be used but not the specific setup parameters. The design evidence, which may be included in the technical specification, will provide details of the proposed solution and appropriate tools will be used given the nature of the product/service, system or process. The design evidence may lack appropriate detail to implement the solution and some consideration for sustainability will be made. For example, the material used in an additive manufacturing process may be ABS as it is easily recycled. Overall, the solution will be logically structured and coherent; however, it may be basic in parts and it may contain minor inaccuracies such as rounding errors or inconsistent units and some engineering terminology may be inaccurate. For example, students may have used the term 'absolute' when 'relative' was intended within a CNC program.

Learning aim C

For distinction standard, there will be detailed evidence of refinements being made to the solution during the process to optimise it. For example, the orientation of a component for a jig on the bed of an additive manufacturing machine may be altered to reduce the amount of support material and post-processing requirements.

Students will monitor progress against their project plans and will optimise milestones taking into account issues and risks that arise during the project implementation. Relevant behaviours will be applied to a consistently high standard throughout the process. For example, students will anticipate risks before they arise, taking appropriate action to resolve risks and issues in a structured way and acting appropriately at all times in the workshop.

Overall, the final solution will be presented in a concise portfolio of evidence that is logically structured, and conclusions will demonstrate that the solution is optimised. Any minor inaccuracies, such as rounding errors or follow-through errors, will occur infrequently if at all. Units and engineering terminology will be accurate and used appropriately throughout. For example, all drawings for a jig will be dimensioned in millimetres, with tight and reasonable tolerances. If errors are identified then students will identify the source of the error, for example a programming mistake, and take corrective action.

For merit standard, the final solution will be generally fit for purpose. For example, the jig may not conform to some aspects of the specification due to minor engineering drawing errors that have been compounded by further minor tolerance errors while machining parts, meaning that components do not locate entirely as intended.

Students will monitor progress against their project plans taking into account issues and risks that arise during the project implementation. Relevant behaviours will be effectively applied throughout the process. For example, Students will take the initiative to resolve issues as they occur, tracking the project and update the project monitoring documentation and risk and issue records as required whilst undertaking the project in a structured way.

Overall, the final solution will be presented in a portfolio of evidence that is logically structured, and conclusions will demonstrate that the solution is generally fit for purpose. It will include justification of any improvements to the processes and behaviours that could be applied next time. However, the evidence may contain minor inaccuracies, such as rounding errors or a limited number of follow-through errors. Units and engineering terminology will be accurate and used appropriately.

For pass standard, the solution will only be partially fit for purpose. For example, some parts of the jig may have been machined inaccurately meaning that not all aspects of the jig can be assembled into a working solution.

Some monitoring and updating of milestones and project risks will be documented and some relevant behaviours will be applied during the process. For example, students will take appropriate responsibility to undertake processes safely and to submit work on time.

Overall, the final solution will be presented in a portfolio of evidence that is logically structured and the conclusion will demonstrate that the solution is mostly appropriate given the technical criteria. However, it may be basic in parts, it may contain minor inaccuracies, such as rounding errors or inconsistent units, and the engineering terminology will be limited and may be inaccurate.

Links to other units

This assessment for this unit allows students to draw on knowledge, understanding and skills developed from:

Unit 1: Principles of Engineering

Unit 2: Engineering Applications

5 Planning your programme

Supporting you in planning and implementing your programme

There will be lots of free teaching and learning support to help you deliver the new qualifications, including:

- Our Planning and Teaching Guide will help you to plan how to deliver the content and assessments that make up the Pearson Level 3 Alternative Academic Qualification BTEC National in Engineering (Extended Certificate) qualification. It also highlights opportunities to develop the transferable skills identified within the units in this specification.
- Sample Assessment materials are available for each external unit to help you to plan and prepare for assessments.
- Our mapping document highlights key differences between the new qualification and BTEC Level 3 National Extended Certificate in Engineering (601/7584/9), which this qualification replaces.

Is there a student entry requirement?

As a centre it is your responsibility to ensure that students who are recruited have a reasonable expectation of success on the programme. There are no formal entry requirements but we expect students to have qualifications at or equivalent to Level 2.

Students are most likely to succeed if they have:

- five GCSEs at good grades, and/or
- BTEC qualification(s) at Level 2
- achievement in English and mathematics through GCSE or Functional Skills.

Students may demonstrate ability to succeed in various ways. For example, students may have relevant work experience or specific aptitude shown through diagnostic tests or non-educational experience.

6 Understanding the qualification grade

Awarding and reporting for the qualification

This section explains the rules that we apply in awarding a qualification and in providing an overall qualification grade for each student. It shows how all the qualifications in this sector are graded.

The awarding and certification of these qualifications will comply with regulatory requirements.

Eligibility for an award

In order to be awarded a qualification, a student must:

- complete and **have an outcome** (D, M, P, N or U) for all units within a valid combination
- achieve the **minimum number of points** at a grade threshold.

Award of the qualification grade

The final grade awarded for a qualification represents an aggregation of a student's performance across the qualification. As the qualification grade is an aggregate of the total performance, there is some element of compensation in that a higher performance in some units may be balanced by a lower outcome in others.

BTEC Nationals are Level 3 qualifications and are awarded at the grade ranges shown in the table below.

Qualification	Available grade range
Extended Certificate	P to D*

The *Award of qualification grade* table, shown further on in this section, shows the minimum thresholds for calculating these grades. The table will be kept under review over the lifetime of the qualification. The most up-to-date table will be issued on our website.

Pearson will monitor the qualification standard and reserves the right to make appropriate adjustments.

Students who do not meet the minimum requirements for a qualification grade to be awarded will be recorded as Unclassified (U) and will not be certificated. They may receive a Notification of Performance for individual units. The *Information Manual* gives full information.

Points available for internal units

The table below shows the number of **points** available for internal units. For each internal unit, points are allocated depending on the grade awarded.

Grade	Unit size (60 GLH)
U	0
Pass	6
Merit	10
Distinction	16

Grade	Unit size (120 GLH)
U	0
Pass	12
Merit	20
Distinction	32

Points available for external units

Raw marks from the external units will be awarded **points** based on performance in the assessment. The table below shows the **minimum number of points** available for each grade in the external units.

Grade	Unit size (60 GLH)
U	0
Near Pass	4
Pass	6
Merit	10
Distinction	16

Grade	Unit size (120 GLH)
U	0
Near Pass	8
Pass	12
Merit	20
Distinction	32

Pearson will automatically calculate the points for each external unit once the external assessment has been marked and grade boundaries have been set. For more details about how we set grade boundaries in the external assessment please go to our website.

Claiming the qualification grade

Subject to eligibility, Pearson will automatically calculate the qualification grade for your students when the internal unit grades are submitted and the qualification claim is made. Students will be awarded qualification grades for achieving the sufficient number of points (with valid combinations) within the ranges shown in the relevant *Award of qualification grade* table for the cohort.

Award of qualification grade

Applicable for registration from August 2025.

Extended Certificate (360 GLH)

Grade	Points threshold
U	0
Pass	36
Merit	52
Distinction	74
Distinction *	90

The table is subject to review over the lifetime of the qualification. The most up-to-date version will be issued on our website.

Example grading table for Pearson Level 3 Alternative Academic Qualification BTEC National in Engineering (Extended Certificate)

Unit number	GLH	Type (Int/Ext)	Grade	Unit points
1	120	Ext	Distinction	32
2	60	Ext	Near Pass	4
3	120	Int	Pass	12
4	60	Int	Merit	10
TOTAL	360		Merit	58

Appendix 1 Glossary of terms used for internally assessed units

Term	Definition
Adequate	Student work is satisfactory or acceptable in quality and quantity.
Analyse	Students break the issue/situation down into the key elements and show their understanding of the issues/situation applied to the scenario/context. Responses would be significantly beyond generic.
Apply/use/employ	Students implement a method, technique, process or approach in an activity.
Assess	Students give careful consideration to all the factors or events that apply, identify which are the most important or relevant and make a judgement on the importance of the factors.
Carry out	Students demonstrate skills through practical activities, in line with certain requirements.
Clear/ly	The qualities required are well demonstrated, unambiguous and beyond a basic level.
Coherent	Student intentions are clear, logically structured and can be interpreted by others.
Compare	Students show knowledge and understanding by identifying the main factors relating to two or more items/situations or aspects of a subject that is extended with the required explanations, e.g, similarities/differences, advantages/disadvantages, impacts.
Comprehensive	Used to describe either scope or depth, e.g. <ul style="list-style-type: none"> • Student work is well developed and thorough covering all aspects/information in terms of both depth and breadth Or: <ul style="list-style-type: none"> • Students demonstrate in-depth and accurate understanding of the aspects being assessed.
Confident	Student work demonstrates well-developed and secure application of skills or processes that are significantly beyond a basic level.
Consistent	Students demonstrate reliable and constant practice that maintains a set standard.
Create/produce	Students generate an idea/outcome to specific criteria.
Demonstrate	Students carry out and apply knowledge, understanding and/or skills in a practical situation.
Describe	Students provide an account of something, or highlight a number of key features of a given topic or process that shows a level of understanding.
Detailed	Students cover most if not all of the expected requirements and demonstrate a high level of understanding.

Term	Definition
Develop	Students apply a process of improving/progressing skills, concepts or work in order to produce outcomes.
Discuss	An issue, situation, process will be presented and the student will need to break the issue/situation/process down into the key elements, show their understanding of the issues/situation/process applied to the scenario/context (so generic answers are not acceptable), and show interrelationship in their answers.
Effective	Students demonstrate skills or provide outcomes that are well developed with a range of proficient qualities and that achieves objectives
Evaluate	Students consider various aspects of a subject's qualities in relation to its context such as: strengths or weaknesses, advantages or disadvantages, pros or cons. They will come to a judgement supported by evidence which will often be in the form of a conclusion.
Examine	Students demonstrate an ability to thoroughly inspect something in order to determine its qualities beyond a basic exploration.
Explain	Students can give an insight into the topic showing some level of understanding by providing reasons or examples.
Explore	Students undertake practical research or investigation to develop their skills or understanding of the topic/activity.
Implement	Students take actions or measures to put something into effect.
Investigate	Students perform a systematic inquiry into a topic using research skills, usually to demonstrate their understanding of a topic.
Justify	Students give relevant and logical reasons or evidence to support their actions or opinions.
Partial/some	To an extent, but not completely. Students do not include all of the requirements.
Perform	Students demonstrate a range of skills required to complete a given activity.
Prepare	Students organise a task/equipment/individuals/activities in advance of carrying it out.
Realistic/feasible	Students demonstrate insight into the logistics and manageability of proposals/plans/objectives/ideas and show consideration of the potential to achieve the outcomes.
Refine/optimize	Students make considered improvements to outcomes.
Review	Students consider evidence in order to make judgements about the qualities.
Understand	Students demonstrate insight or ability to interpret a subject.
Undertake	Students demonstrate skills through practical activities, often referring to given processes or techniques.

Appendix 2 Transferable Skills framework

Code = transferable skill initials-skill cluster initials

Managing yourself

Code	Skill cluster	Performance Descriptor
MY-TPR	Taking personal responsibility	<ul style="list-style-type: none"> • Demonstrates understanding of their role and responsibilities and the expected standards of behaviour. • Demonstrates compliance with codes of conduct and ways of working. • Makes use of available resources to complete tasks. • Manages their time to meet deadlines and the required standards. • Demonstrates accountability for their decisions or actions.
MY-PS&R	Personal strengths and resilience	<ul style="list-style-type: none"> • Identifies own personal strengths and demonstrates the ability to use these in relevant areas. • Demonstrates the ability to adapt own mindset and actions to changing situations or factors. • Uses challenges as learning opportunities.

Code	Skill cluster	Performance Descriptor
MY-COP	Career orientation planning	<ul style="list-style-type: none"> • Undertakes research to understand the types of roles in the sector in which they could work. • Reviews own career plans against personal strengths and identifies areas for development to support progression into selected careers. • Takes part in sector-related experiences to support career planning.
MY-PGS	Personal goal setting	<ul style="list-style-type: none"> • Sets SMART goals using relevant evidence and information. • Reviews progress against goals and identifies realistic areas for improvement. • Seeks feedback from others to improve own performance.

Effective learning

Code	Skill cluster	Performance Descriptor
EL-MOL	Managing own learning	<ul style="list-style-type: none"> • Maintains a focus on own learning objectives when completing a task. • Demonstrates the ability to work independently to complete tasks. • Reviews and applies learning from successful and unsuccessful outcomes to be effective in subsequent tasks.
EL-CL	Continuous learning	<ul style="list-style-type: none"> • Engages with others to obtain feedback about own learning progress. • Responds positively to feedback on learning progress from others. • Monitors own learning and performance over the short and medium term.
EL-SRS	Secondary research skills	<ul style="list-style-type: none"> • Define the research topic or question. • Uses valid and reliable sources to collate secondary data. • Interprets secondary data and draws valid conclusions. • Produces a reference list and cites sources appropriately.
EL-PRS	Primary research skills	<ul style="list-style-type: none"> • Define the research topic or question. • Carries out primary data collection using appropriate and ethical research methodology. • Interprets primary data to draw valid conclusions.

Interpersonal skills

Code	Skill cluster	Performance Descriptor
IS-WC	Written communication	<ul style="list-style-type: none"> • Produces clear formal written communication using appropriate language and tone to suit purpose.
IS-V&NC	Verbal and non-verbal communications	<ul style="list-style-type: none"> • Uses verbal communication skills confidently to suit audience and purpose. • Uses body language and non-verbal cues effectively. • Uses active listening skills and checks understanding when interacting with others.
IS-T	Teamwork	<ul style="list-style-type: none"> • Engages positively with team members to understand shared goals and own roles and responsibilities. • Respectfully consider the views of team members and consistently shows courtesy and fairness. • Completes activities in line with agreed role and responsibilities. • Provide support to team members to achieve shared goals.
IS-C&SI	Cultural and social intelligence	<ul style="list-style-type: none"> • Demonstrates awareness of own cultural and social biases. • Demonstrates diversity, tolerance and inclusivity values in their approach to working with others.

Solving problems

Code	Skill cluster	Performance Descriptor
SP-CT	Critical thinking	<ul style="list-style-type: none"> • Demonstrates understanding of the problem or issue to be addressed. • Makes uses of relevant information to build ideas and arguments. • Assesses the importance, relevance and/or credibility of information. • Analyses, interprets and evaluates information to present reasoned conclusions.
SP-PS	Problem solving	<ul style="list-style-type: none"> • Presents a clear definition of the problem. • Gathers relevant information to formulate proposed solutions. • Selects relevant and significant information to formulate proposed solutions. • Identifies negative and positive implications of proposed solutions. • Presents and justifies selected solutions to problems.
SP-C&I	Creativity and innovation	<ul style="list-style-type: none"> • Identifies new and relevant ideas to help solve a problem. • Refines ideas into workable solutions based on test results and/or feedback.

Appendix 3 Digital Skills framework

Problem solving

Using digital tools to analyse and solve problems:

Performance descriptor	Unit mapping
<p>Use digital tools and techniques for research, collaboration and resolution of problems.</p>	<p>Unit 2: A2.2 Sales and marketing Unit 2: A2.3 Design of engineering products and services Unit 3: CAD and 3D parametric modelling Unit 4: A2 Project idea generation and solution development Unit 4: B1 Planning and monitoring project management processes Unit 4: B4 Design information</p>
<p>Have up-to-date knowledge of ways that technology is used within a sector.</p>	<p>Unit 2: A2.7 Quality management Unit 2: A3.1 Robotics Unit 2: A3.2 Virtual reality Unit 2: A3.3 Augmented reality Unit 2: A3.6 Artificial intelligence Unit 2: A3.7 Drawing Unit 2: A3.8 Digital twinning Unit 3: CAD and 3D parametric modelling Unit 3: B3 Developing 3-dimensional components Unit 3: B4 Developing a 3-dimensional assembled model Unit 4: B4 Design information Unit 4: C1 Undertake and test the solution to the problem</p>

Performance descriptor	Unit mapping
Present ideas and finding using digital tools.	Unit 3: C1 Two-dimensional detailed computer-aided drawings of an engineered product Unit 4: B4 Design information Unit 4: C1 Undertake and test the solution to the problem
Use digital tools to manipulate data.	Unit 3: CAD and 3D parametric modelling Unit 3: CAD and 3D parametric modelling Unit 3: B3 Developing 3-dimensional components Unit 3: B4 Developing a 3-dimensional assembled model Unit 4: A2 Project idea generation and solution development

Digital collaboration and communication

Using digital tools to communicate and share information with stakeholders:

Performance descriptor	Unit mapping
Understand and use digital collaboration and communication platforms.	Unit 2 A3.1 Robotics Unit 2 A3.2 Virtual Reality Unit 2 A3.3 Augmented Reality Unit 2 A3.4 Cloud computing Unit 2 A3.5 Internet of Things (IoT) Unit 2 A3.6 Artificial Intelligence (AI) Unit 2 A3.7 3D printing Unit 2 A3.8 Digital twinning Unit 3 B3 Developing 3-dimensional components Unit 3 B4 Developing a 3-dimensional assembled model Unit 3 C1 Two-dimensional detailed computer-aided drawings of an engineered product Unit 4 C1 Undertake and test the solution to the problem
Use collaboration tools to meet with, share and collaborate with customers and colleagues.	Unit 2, A2.2 Sales and marketing Unit 2 A2.3 Design of engineering products and services Unit 2 A2.10 Information management Unit 3 A4 Generating initial design ideas Unit 3 C2 Presentation and communication skills Unit 4 A2 Project idea generation and solution development Unit 4 B1 Planning and monitoring project management processes Unit 4 B4 Design information Unit 4 C3 Present a solution to the problem

Transacting digitally

Using digital tools to set up accounts and pay for goods/services:

Performance descriptor	Unit mapping
Use online systems to access and update digital records.	Unit 2: A2.10 Information management Unit 2 A3.4 Cloud computing Unit 2: A3.5 Internet of Things (IoT) Unit 2: A3.6 Artificial Intelligence (AI) Unit 3: A5 Modelling design solutions
Set-up accounts to complete transactions.	

Digital security

Identify threats and keep digital tools safe:

Performance descriptor	Unit mapping
Understand the types of malware.	
Understand the threats involved in carrying out online activities.	Unit 2 A3.4 Cloud computing
Protect personal and organisation information and data.	Unit 2: A2.10 Information management Unit 2 A3.4 Cloud computing
Keeping systems secure.	Unit 2: A2.10 Information management Unit 2 A3.1 Robotics Unit 2 A3.2 Virtual Reality Unit 2 A3.3 Augmented Reality Unit 2 A3.5 Internet of Things (IoT) Unit 2 A3.6 Artificial Intelligence (AI) Unit 2 A3.7 3D printing Unit 2 A3.8 Digital twinning Unit 2 B3.4 Manufacturing processes/Machining Unit 2 B3.5 Manufacturing processes/Cutting Unit 2 B3.6 Manufacturing processes/Additive manufacturing

Handling data safely and securely

Follow correct procedures when handling personal and organisational data:

Performance descriptor	Unit mapping
Manage passwords and keep them secure.	Unit 2 A2.4 Process monitoring and control Unit 2 A2.10 Information management Unit 2 A3.4 Cloud computing
Identify website and services that are secure and insecure.	Unit 2: A2.2 Sales and marketing
Understand the digital policy for a sector.	Unit 2 A2.4 Process monitoring and control Unit 2 A2.10 Information management Unit 2 A3.4 Cloud computing Unit 2 A3.5 Internet of Things (IoT) Unit 2 A3.6 Artificial Intelligence (AI) Unit 2 A3.8 Digital twinning Unit 2 B3.4 Manufacturing processes/Machining Unit 2 B3.5 Manufacturing processes/Cutting Unit 2 B3.6 Manufacturing processes/Additive manufacturing
Understand the impact of online data.	Unit 2: A2.2 Sales and marketing
Understand copyright and intellectual property.	Unit 3: A1: Interpreting product technical requirements

Appendix 4 Sustainability framework

Sustainable development goal	Unit mapping
SDG 1: No poverty	
SDG 2: Zero hunger	
SDG 3: Good health and wellbeing	Unit 2: A1.4 Biomedical Engineering Unit 2: A2.9 Health and Safety Management Unit 3: A1 Interpreting product technical requirements/Health & Safety/ Environmental Legislation Unit 3: A4 Generating initial design ideas/sustainability (waste production, pollution) Unit 4: A3 Feasibility study of solutions
SDG 4: Quality education <i>(in the context of 'promoting sustainable development')</i>	Unit 2: A2.1 Research and Development Unit 2: A2.8 Energy management Unit 2: B1 Materials Unit 2: B3 Manufacturing processes Unit 3: A1 Interpreting product technical requirements/Sustainability factors Unit 3: A4 Generating initial design ideas/sustainability Unit 4: A3 Feasibility study of solutions Unit 4: B1 Planning and monitoring project management processes
SDG 5: Gender equality	
SDG 6: Clean water and sanitation	
SDG 7: Affordable and clean energy	Unit 2: A1.7 Energy Generation Unit 2: A2.8 Energy management
SDG 8: Decent work and economic growth	
SDG 9: Industry, innovation and infrastructure	Unit 2: A1 Engineering Sectors Unit 2: A2.1 Research and Development Unit 2: A2.8 Energy Management

Sustainable development goal	Unit mapping
	Unit 2: A3 Modern and Emerging Technologies Unit 2: B3 Manufacturing Processes Unit 3: A3 The characteristics and applications of manufacturing processes Unit 4: C1 Undertake and test the solution to the problem
SDG 10: Reduced inequalities	
SDG 11: Sustainable cities and communities	
SDG 12: Responsible consumption and production	Unit 2: B1 Materials Unit 2: B2 Properties of Materials Unit 2: B3 Manufacturing Processes
SDG 13: Climate action	
SDG 14: Life below water	
SDG15: Life on land	Unit 2: B3 Manufacturing processes Unit 3: A1 Interpreting product technical requirements / legal requirements e.g. environmental legislation Unit 3: A4 Generating initial design ideas / sustainability Unit 4: A3 Feasibility study of solutions / sustainability e.g. environmental impact of mass production Unit 4: B3 Technical specification (environmental considerations)
SDG 16: Peace, justice and strong institutions	
SDG 17: Partnerships for the goals	

Appendix 5: Formulae and Constants

Laws of indices:

$$a^m \times a^n = a^{(m+n)}$$

$$\frac{a^m}{a^n} = a^{(m-n)}$$

$$(a^m)^n = a^{mn}$$

Laws of logarithms:

$$\log A + \log B = \log AB$$

$$\log A^n = n \log A$$

$$\log A - \log B = \log \frac{A}{B}$$

Factorisation and quadratics:

Quadratic formula
$$x = \frac{-b \pm \sqrt{b^2 - 4ac}}{2a}$$

Trigonometric rules:

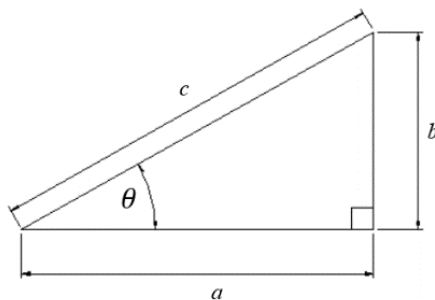

Pythagoras' theorem
$$c^2 = a^2 + b^2$$

Trigonometric functions

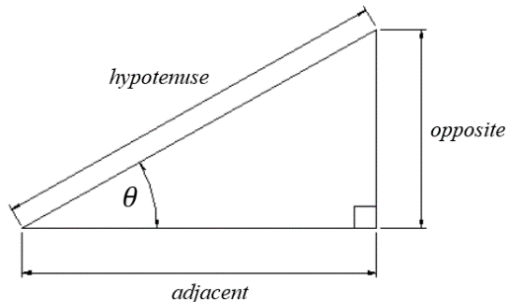

$$\text{Sine } \theta = \frac{\text{Opposite}}{\text{Hypotenuse}} \quad \text{Cos } \theta = \frac{\text{Adjacent}}{\text{Hypotenuse}} \quad \text{Tan } \theta = \frac{\text{Opposite}}{\text{Adjacent}}$$

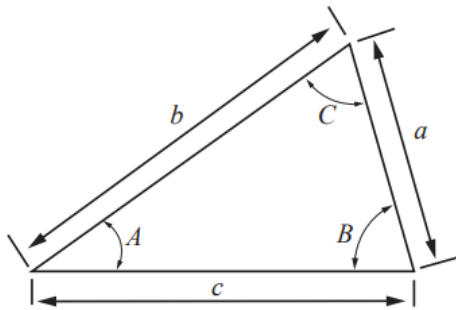

Sine rule

$$\frac{a}{\sin A} = \frac{b}{\sin B} = \frac{c}{\sin C} \quad \text{or} \quad \frac{\sin A}{a} = \frac{\sin B}{b} = \frac{\sin C}{c}$$

Cosine rule

$$a^2 = b^2 + c^2 - 2bc \cos A$$

Angular measurements

Length of arc of a circle

$$s = r \theta$$

(where θ is measured in radians)

Area of a sector

$$A = \frac{1}{2} r^2 \theta$$

(where θ is measured in radians)

Radians to degrees conversion

$$\theta_{(\text{degrees})} = \frac{360 \theta (\text{radians})}{2\pi}$$

Degrees to radians conversion

$$\theta_{(\text{radians})} = \frac{2\pi \theta (\text{degrees})}{360}$$

Mensuration

Volume of a cylinder

$$V = \pi r^2 h$$

Total surface area of a cylinder

$$TSA = 2\pi r h + 2\pi r^2$$

Volume of sphere

$$V = \frac{4}{3}\pi r^3$$

Surface area of a sphere

$$SA = 4\pi r^2$$

Volume of a cone

$$V = \frac{1}{3}\pi r^2 h$$

Curved surface area of cone

$$CSA = \pi r l$$

Area of a rectangle

$$A = b \times h$$

Area of a circle

$$A = \pi r^2$$

Area of a triangle

$$A = \frac{1}{2} b \times h$$

Volume of a cuboid

$$V = b \times h \times d$$

(where b is the width of the cuboid, h is the height and d is the depth)

Volume of a triangular prism

$$A = \frac{1}{2} b \times h \times l$$

(where d is the width of the base, h is the height and l is the length)

Total surface area of a cuboid

$$TSA = 2(b \times h) + 4(b \times d)$$

(where b is the width of the cuboid, h is the height and d is the depth)

Total surface area of a triangular prism

$$TSA = 3(b \times l) + 2 \times \frac{1}{2}(b \times h)$$

(for an equilateral triangle where b is the width of the base, h is the height and l is the length)

Diameter of a circle

$$d = 2r$$

Calculus

Differentiation by standard results

$$\text{if } y = ax^n, \text{ then } \frac{dy}{dx} = nax^{(n-1)}$$

Mechanical Engineering

Static engineering systems

Components of forces in perpendicular directions

$$Fx = F\cos\theta, Fy = F\sin\theta$$

(where θ is measured from the horizontal)

Conditions for static equilibrium

$$\Sigma Fx = 0, \Sigma Fy = 0, \Sigma M = 0$$

Moment of a force

moment = force \times perpendicular distance

Direct stress

$$\sigma = \frac{F}{A}$$

Direct strain

$$\varepsilon = \frac{\Delta L}{L}$$

Shear stress

$$\tau = \frac{F}{A}$$

Shear strain

$$\gamma = \frac{a}{b}$$

Young's Modulus (modulus of elasticity)

$$E = \frac{\sigma}{\varepsilon}$$

Modulus of rigidity

$$G = \frac{\tau}{\gamma}$$

Dynamic engineering systems

Equations for linear motion with uniform acceleration

v = final velocity, u = initial velocity, a = acceleration, t = time and s = distance

$$v = u + at$$

$$s = ut + \frac{1}{2}at^2$$

$$v^2 = u^2 + 2as$$

$$s = \frac{1}{2}(u + v)t$$

Dynamic parameters and principles

Force

$$F = ma$$

Rotational inertia

$$I = kmr^2$$

Where the inertial constant is:

$k = 0.5$ for a solid cylinder (flywheel)

$k = 1$ for a thin walled hollow cylinder (along its axis of rotation)

Torque (T)

$$T = Fd$$

Mechanical work

$$W = Fs$$

Mechanical power (average and instantaneous)

$$P = \frac{W}{T}, P = Fv$$

Mechanical efficiency

$$\eta = \frac{P_{out}}{P_{in}}$$

Gravitational potential energy

$$PE = mgh$$

Kinetic energy

$$KE = \frac{1}{2}mv^2$$

Momentum

$$p = mv$$

Conservation of momentum

$$m_1u_1 + m_2u_2 = m_1v_1 + m_2v_2$$

Angular parameters

Angular velocity

$$\omega = \frac{\theta}{t} = \frac{s}{rt} = \frac{v}{r}$$

Centripetal acceleration

$$a = \omega^2r \text{ or } a = \frac{v^2}{r}$$

Uniform circular motion power

$$P = T\omega$$

Rotational kinetic energy

$$KE = \frac{1}{2}I\omega^2$$

Angular frequency

$$f = \frac{\omega}{2\pi}$$

Lifting machines

Velocity ratio $VR = \frac{\text{driver}}{\text{driven}} = \frac{\text{distance moved by effort}}{\text{distance moved by load}}$

Mechanical advantage $MA = \frac{\text{load}}{\text{effort}}$

Force to overcome friction $F = \mu N$ (where N is the normal force)

Fluid engineering systems

Hydrostatic thrust on an immersed plane surface $F = \rho g A x$

Where the constant x is:

$$x = \frac{h}{2}$$

for a rectangular retaining surface with one edge in the free surface of a liquid

Fluid flow in a gradually tapering pipe:

Continuity of volumetric flow $A_1 v_1 = A_2 v_2$

Continuity of mass flow $\rho A_1 v_1 = \rho A_2 v_2$

Buoyant force $F_b = \rho g V$

Density $\rho = \frac{m}{V}$

Electronic and Electrical Engineering

Direct current electricity

Charge/electron flow (current)

$$I = \frac{q}{t}$$

Coulomb's law

$$F = \frac{q_1 q_2}{4\pi\epsilon_0 r^2}$$

Resistivity

$$R = \frac{\rho l}{A}$$

Temperature coefficient of resistance

$$\frac{\Delta R}{R_0} = \alpha \Delta T$$

Resistors in parallel

$$\frac{1}{R_T} = \frac{1}{R_1} + \frac{1}{R_2} + \frac{1}{R_3} \dots$$

Electric field strength

$$E = \frac{F}{q} \quad \text{or} \quad E = \frac{v}{d}$$

Direct current circuit theory

Ohm's law

$$I = \frac{V}{R}, \quad V = IR, \quad R = \frac{V}{I}$$

Electrical power

$$P = IV, \quad P = I^2 R, \quad P = \frac{V^2}{R}$$

Electrical efficiency

$$\eta = \frac{P_{out}}{P_{in}}$$

Kirchhoff's current law

$$V = V_1 + V_2 + V_3 \dots \quad \text{or} \quad \sum PD = \sum IR$$

Kirchhoff's current law

$$I = I_1 + I_2 + I_3 \dots$$

Capacitance

Capacitance	$C = \frac{\epsilon A}{d}$
Charge stored on a capacitor	$Q = CV$
Energy stored in capacitors	$W = \frac{1}{2}CV^2$
Time constant	$\tau = RC$
Capacitors in series	$\frac{1}{C_T} = \frac{1}{C_1} + \frac{1}{C_2} + \frac{1}{C_3} \dots$
Capacitors in parallel	$C_T = C_1 + C_2 + C_3 \dots$
Voltage decay on Capacitor discharge	$V_c = V_s e^{(-t/\tau)}$ (where V_c = capacitor voltage and V_s = supply voltage)

Magnetism and electromagnetic

Electric field strength	$E = \frac{F}{q}$ or $E = \frac{V}{d}$ for uniform electric fields
Flux density	$B = \frac{\phi}{A}$
Magnetomotive force (mmf)	$F_m = NI$
Permeability	$\frac{B}{H} = \mu_0 \mu_r$
Reluctance	$S = \frac{F_m}{\phi}$
Magnetic field strength	$H = \frac{NI}{l}$
Induced EMF	$E = Blv$ or $E = -N \frac{d\phi}{dt} = -L \frac{di}{dt}$
Energy stored in an inductor	$W = \frac{1}{2}LI^2$
Inductance of a coil	$L = N \frac{\phi}{I}$
Transformer equation	$\frac{V_1}{V_2} = \frac{N_1}{N_2}$

Single-phase alternating current theory

Time period	$T = \frac{1}{f}$
Capacitive reactance	$X_C = \frac{1}{2\pi fC}$
Inductive reactance	$X_L = 2\pi fL$
Ohm's Law AC circuits	$I = \frac{V}{Z}$
Root mean square voltage	r. m. s. voltage = $\frac{\text{peak voltage}}{\sqrt{2}}$
Total impedance of an inductor in series with a resistance	$Z = \sqrt{X_L^2 + R^2}$
Total impedance of a capacitor in series with a resistance	$Z = \sqrt{X_C^2 + R^2}$
Average value	Average value = $\frac{2}{\pi} \times \text{maximum value}$
Form factor	Form factor = $\frac{\text{r.m.s.value}}{\text{average value}}$

Physical constants

Acceleration due to gravity	$g = 9.81 \text{ m/s}^2$
Permittivity of free space	$\epsilon_0 = 8.85 \times 10^{-12} \text{ F/m}$
Permeability of free space	$\mu_0 = 4\pi \times 10^{-7} \text{ H/m}$

For information about Pearson Qualifications, including Pearson Edexcel, and BTEC visit qualifications.pearson.com

Edexcel and BTEC are registered trademarks of Pearson Education Limited

Pearson Education Limited. Registered in England and Wales No. 872828
Registered Office: 80 Strand, London WC2R 0RL.

VAT Reg No GB 278 537121

Cover image © Shutterstock



Publication code:
VQ000271